

CITY OF COCKBURN

GUIDELINES AND STANDARDS

for the Design, Construction and Handover of
Subdivision within the Municipality

Contents:

Introduction

- 1.0 Stormwater Drainage**
- 2.0 Earthworks and Site Regrading**
- 3.0 Road Design and Layout**
- 4.0 Public Open Space**

November 2013

Page intentionally blank.

Contents

INTRODUCTION	4
1.0 Stormwater Drainage.....	4
2.0 Earthworks and Site Regrading	8
3.0 Road design and layout.....	10
4.0 Public Open Space	17
SUBDIVISIONS CONDITIONS TEMPLATE	19
Certificate of Compliance	24

Page intentionally blank.

INTRODUCTION

This document has been compiled to assist development consultants to meet the expectations of the City of Cockburn in the development of residential and industrial subdivisions. The intention is not to supplant other texts on subdivisional development but to provide detail to what are generally given as broad statements.

The City of Cockburn is the authority responsible for the future care, control and management of the road, POS and stormwater drainage infrastructure constructed to enable the subdivision of land. The City therefore retains the right to require a subdivision to be constructed to the standards detailed hereunder and to its entire satisfaction.

The Design Engineer is responsible for compliance with this document, associated publications and statutory requirements. Council's acceptance of a design submission shall not relieve the Design Engineer of this responsibility or the responsibility for any discrepancies, errors or omissions in the submission or from the adequacy of the design.

The City acknowledges that the guidelines published by IPWEA (Edition No. 2 – June 2009) are to be considered as the minimum standard for subdivision development and are to be read in conjunction with this document and other policies and legislations relevant to Agencies associated with subdivisional approvals.

All designs submitted for approval will be checked against these guidelines and those found wanting will be returned for revision. This is not to imply innovation will not be considered, but good supportive evidence must accompany any proposal. As this is a living document and subject to changes, positive, constructive criticism is welcome.

1.0 Stormwater Drainage

1.1 General

- 1.1.1 Designers must develop and submit on a plan a drainage strategy for the whole of the catchment. The plan must include groundwater contours if they will affect the design.
- 1.1.2 The stormwater drainage system is to be designed in accordance with the manual 'Australian Rainfall and Runoff, 1987' and the overland flow path is to be shown on the catchment plan required in section 1.1.1 above.
- 1.1.3 The major system is to be designed so that the floor levels of all habitable buildings are a minimum of 300mm above the 100-year ARI storm flood level.
- 1.1.4 Storm drainage management reports for various areas are available on Council's website.

1.2 Design

- 1.2.1 Design calculations are to be submitted with the design drawings.
- 1.2.2 Design average recurrence intervals shall be:-
- 10 years for commercial/industrial area minor drainage
 - 5 years for residential minor drainage.
- 1.2.3 Coefficients of runoff from sandy soils shall be: -
- Road reserves 0.9
 - Coefficients of runoff not covered above should be calculated in accordance with Section 14.5 of AR&R 1987
 - For catchments greater than 15ha methods other than the Rational Method are to be used for calculating flows.
- 1.2.4 Time of concentration: – min. 6 minutes.
- 1.2.5 The minimum pipe velocity should be sufficient to sustain self-cleaning.
- 1.2.6 Minimum permissible pipe size is 225mm diameter.
- 1.2.7 Longitudinal pipelines shall not be placed under road pavements except to serve an inlet pit in the opposing gutter.
- 1.2.8 All stormwater drainage pipes shall be of reinforced concrete. The City Engineer may approve alternate materials if convincing supporting data is provided.
- 1.2.9 The maximum water level (hydraulic grade line) in an inlet pit shall be limited to 150mm below the inlet and to 150mm below the underside of a junction pit lid.
- 1.2.10 Inlet pits shall match the kerbing with the front of the lid on the kerb face line (not indented) and shall be bicycle friendly (without deflector flutes).
- 1.2.11 Minimum cover over pipes shall be 600mm for class 2 pipes and 400 mm for class 4 unless otherwise specified by the manufacturer.
- 1.2.12 Pipe alignments in the verge shall conform to the “Utility Providers Code of Practice WA”.
- 1.2.13 In areas where the base of a pit intersects or is above the AAMGL the base shall be 600mm below the lowest pipe invert level and the seep hole in the base shall be 600mm diameter to aid infiltration. The base will be laid on a 300mm depth of 20mm granite aggregate wrapped in geotextile. The seep hole is to be filled with loose 20mm granite aggregate. (See Fig. 1 below)
- 1.2.14 In all other cases pits are to be benched (chased).

1.2.15 Pipes shall be sized disregarding any possible infiltration volume as described in 1.2.13 above but the storage between pipe invert and the base may be considered.

1.3 Layout

1.3.1 Inlet pits shall be placed immediately upstream of all intersections where the catchment > 150m².

1.3.2 Inlet and junction pits should be placed mid-block to avoid future clashes with driveways, etc.

1.3.3 Inlet pits should be placed to limit gutter flow to a maximum of 1.5m width or to limit the volume to the inlet capacity of the inlet pit, whichever is the least.

1.3.4 The maximum spacing of inlet pits irrespective of gutter flows shall be 100m on a crowned cross-section and 60m on a road with one-way crossfall.

1.3.5 All drainage lines to be placed under existing roads are to be bored.

1.3.6 Junction pits are to be placed clear of the carriageway.

1.3.7 Every effort is to be made to keep all junction pit structures clear of the road pavement.

1.3.8 Combination pits shall be placed at all “trapped” low points.

1.4 Subsoil Drainage

1.4.1 Finished lot levels are to be a minimum of 1.2m above the pre-development AAMGL.

1.4.2 If the land is to be filled then subsoil drainage is to be placed to maintain the AAMGL at its pre-development level. The pre-development AAMGL is not to be lowered.

1.4.3 Soil permeability tests are to be taken on site and used to determine the spacing of subsoil drainage lines. Data from such tests and the calculations are to be submitted.

Compensating Basins and Sumps

- 1.4.4 Council's philosophy is to maximise localised recharge of the ground water.
- 1.4.5 Lined basins (ornamental lakes) are prohibited for use as drainage basins.
- 1.4.6 Drainage detention basins are to be placed at the lowest point of the catchment and are to be designed to take the total catchment runoff from a critical storm event.
- 1.4.7 Compensating basins are to be placed in the catchment when the pipe size becomes greater than 1050mm dia. or the depth to invert greater than 3m.
- 1.4.8 An open basin (or grassed swale) shall have batters not exceeding a 1 in 7 slope over a maximum distance of 50m.
- 1.4.9 Open basins shall be landscaped compatible with passive recreation except where the conservation value of the natural vegetation is high. (Refer to Section 4.4)
- 1.4.10 The last Junction pit in the road reserve before the outlet into an open drainage basin shall be fitted with a gross pollution trap.
- 1.4.11 To maximise infiltration the compensating basin capacity shall be sufficient to accommodate a 1 in 10 ARI storm below the outlet invert.
- 1.4.12 Infiltration rates shall be determined by site testing and due consideration shall be given to the AAMGL for the area. Test results and calculations are to be submitted with the overall drainage calculations.
- 1.4.13 Prior to adopting an infiltration rate consideration should be given to the effect of sedimentation over time. Information on the adopted rate, including its source, should be submitted with the design.
- 1.4.14 Where acceptable batter slopes are not possible, a fenced basin shall be installed.
- 1.4.15 In a fenced basin, the batter slope shall be the natural angle of repose but shall not exceed 1 in 2.
- 1.4.16 For stand-alone basins, fencing shall be a minimum height of 1800mm and can be constructed of masonry seated colourbond metal, supersix fibro-cement (capped and painted both sides), brick or masonry. Piers shall be provided for all types of fencing and shall be no more than 300mm above the fence line and be at no greater than 7.5m centres for brick and masonry and 6m for all other fences. For basins incorporated in passive recreation areas the fencing shall be acceptable to Council's Parks Manager.

1.4.17 The basin shall be provided with a matching lockable, theft proof gate, a concrete crossover and a constructed ramp of 150mm compacted limestone to the base.

1.4.18 It shall be planted with suitable native trees and shrubs between the fence and the design top water level.

2.0 Earthworks and Site Regrading

2.1 Earthworks and site regrading shall be undertaken to: -

2.1.1 Prevent the flooding of low-lying areas.

2.1.2 Provide an overland flow path for major storm events.

2.1.3 Regrade slopes to facilitate the proposed development.

2.1.4 To provide adequate cover over stormwater drainage pipes as recommended by the manufacturers.

2.1.5 To provide the required freeboard for major storm events.

2.1.6 The protection of significant site features.

2.2 Design Requirements

2.2.1 The plan must show existing and proposed contours.

2.2.2 Measures to protect the existing environment are to be detailed and to be supplied to the City by digital means.

2.2.3 Any trees proposed for removal are to be clearly shown.

2.2.4 Topsoil is to be removed stockpiled and respread at completion of works.

2.2.5 The proposed stabilisation details are to be shown on the plan.

2.2.6 A dust management plan, including the protection of surrounding properties, is to be submitted for approval with the earthwork drawings.

2.2.7 Finished lot levels are to be no less than 1.2m above the AAMGL or the control ground water level as the case may be.

2.3 Guidelines

2.3.1 Prior to placing fill material, existing ground conditions are to be investigated by a Geotechnical Engineer, as a minimum by mechanical intrusion, and any material unsuitable for purpose is to be mapped and then removed (All details to be supplied to the City by digital means).

- 2.3.2 Fill material is to be clean, free draining, sand, free from large rocks, stumps, organic matter and other deleterious debris. Not less than 35% of the material by weight shall pass the 4.75mm sieve and not more than 5% by weight shall pass the 75-micron sieve. The plasticity of the material passing the 435-micron sieve shall not exceed 6.
- 2.3.3 Fill material is to be prevented from spilling over onto surrounding properties.
- 2.3.4 The fill material shall be placed in layers no thicker than 300mm and each layer shall be compacted to 95% standard dry density when measured with a calibrated penetrometer. (All details to be supplied to the City by digital means).
- 2.3.5 Stockpile areas are to be treated with erosion and dust control measures.
- 2.3.6 Retaining walls are to be designed and certified by a practicing structural engineer and signed detail drawings are to be submitted for Council's records.
- 2.3.7 The design engineer is to provide a certificate with supporting documentation and test results signed by a professional Geotechnical Engineer confirming that the land to be released is suitable for its intended purpose.

3.0 Road design and layout

3.1 General design criteria

- 3.1.1 Minimum road reserve width for residential streets is 15m except roads abutting POS road reserve width can be reduced to 13.5m (reduced verge width on POS side).
- 3.1.2 Pavement widths are to conform to the standards set out in the document "Liveable Neighbourhoods" dated June 2000 or as amended except that the minimum carriageway width shall be 5.5m and the minimum intersection kerb radii shall be 12m to accommodate a "Design Single Unit Truck".
- 3.1.3 Cycle ways shall be as required by "Bikeplan"

3.2 Road pavements

- 3.2.1 The road pavement profiles shall be in accordance with IPWEA (Institute of Public Works Engineering Australia) Policy note "Pavement Profiles in Residential Streets" which is as below:

- 200mm average compacted thickness limestone.
- 40mm average compacted thickness 10mm or 14mm dense graded asphalt designed to 35 Marshall blows with a final surface of 25mm average compacted thickness of 7mm dense graded or gap graded asphalt designed to 35 Marshall blows for roads with design traffic less than 5E 5 ESA's

OR

- 35mm or 40mm average compacted thickness 10mm or 14mm dense graded asphalt designed to 35 Marshall blows with a final surface of 30mm of 10mm dense graded asphalt designed to 50 Marshall blows for roads with design traffic greater than 5 E5 ESA's but less than 1.0 E6 ESA's.

Notes:

- *This pavement depth is recommended only in residential streets with sand sub-grades with a minimum depth of 1m to the maximum water table level.*
- *In the case of soils containing silts, clays, peat or in cases closer than 1m to the maximum water table, specific pavement designs should be undertaken in line with Standards Australia/Austrroads Pavement Design Manual or APRG Report No 21, A guide to the design of new pavements for light traffic as applicable.*
- *Where the road carries traffic greater than 1×10^6 equivalent standard axles over a 20 year design life, the pavement profile should be subject to specific design.*

3.2.2 Road pavements are to be of the materials specified above. Brick paving and concrete beams are not allowed in road pavements, but are allowed in the following area; breaks in median islands, as infill in median and splinter islands and in parking nodes. All bricks are to be of an interlocking type and laid on a maximum 30mm sand bedding. Joint infill sand shall be Pave-Lok or similar used to the supplier's specification. Differential settlement between the road pavement, the concrete beam and the paving bricks are to be addressed and nullified.

Red asphalt shall consist of 2% red oxide in a granite mix.

3.2.3 Compaction requirements:

Sub-grade=Sub-grade shall be compacted to not less than 95% of the maximum dry density obtained in the modified maximum dry density compaction tests in accordance with AS 1289.5.2.1-2003 to a min depth of 600mm below bottom of box levels

Limestone=Sub-base shall be compacted to not less than 95% of the maximum dry density obtained in the modified maximum dry density compaction tests in accordance with AS 1289.5.2.1-2003

Asphalt

Asphalt shall be compacted to the following average in situ air voids:-

Asphalt Mix Type	Average in situ air voids
35 blow mixes & gap graded mixes	2.5 to 8.0% (surface layers)
	2.5 to 7.0% (in bottom layers)
5 blow mixes	3.0 to 10.0% (in bottom layers)

3.2.4 Thickness Tolerance:

The average asphalt thickness of cores taken from the asphalt surfacing shall be within + or – 10% of the specified asphalt thickness.

Property	Mix Designation		
	AC7	AC10	AC14
	20 to 30mm thick	30 to 55mm thick	40 to 60mm thick
Grading Limits % passing AS Sieve			
26.5mm			
19.0mm			100
13.2mm		100	90-100
9.5mm	100	90-100	70-90
6.7mm	80-100	80-95	62-75
4.75mm	70-90	65-80	47-67
2.36mm	45-60	45-60	34-52
1.18µm	35-50	35-50	25-41
600µm	22-35	25-40	16-32
300µm	14-25	15-25	9-21
150µm	8-16	7-15	5-13
75µm	5-8	3-10	2-8
Bitumen Content	5.0-7.0	5.0-7.0	4.5-6.5
Marshall Voids (%)	35 blows	2.0-4.5	2.0-4.5
	50 blows	3.0-5.0	3.0-5.0
Minimum Marshall Stability	35 blows	4.0kN	4.0kN
	50 blows	5.5kN	6.5kN
Marshall Flow (mm)	35 blows	2.0-5.0	2.0-5.0
	50 blows	2.0-4.0	2.0-4.0
Marshall Quotient (min) (kN/mm)	35 blows	1.0	1.0
	50 blows	1.7	1.7

Recommendations for 20 year design traffic

Range/Type	Mix	Bitumen Type
Greater than 50,000 ESA	50 blows	Class 170-320
Less than 50,000 ESA	35 blows	Class 170-320
Maintenance	50 blows	Class 170-320

3.2.4 Gradients

Minimum longitudinal gradient – 0.5%

Turning circles in cul-de-sacs – less than or equal to 5%

Through intersections – where practical less than or equal to 4%

Absolute maximum longitudinal gradients:

Access Place/Way – 16%

Local distributor - 12%

District distributor – 8%

3.4 Vertical curves

Vertical curves shall be placed at all grade changes exceeding 1%.

Minimum lengths: -

	General	At intersections
Access Place/Way	25m	6m
Local Distributor	35m	12m
District Distributor	50m	20m

3.5 Horizontal Curves

Horizontal curve dimensions are given as centreline measurements.

Design Speed	Curve – no tangents Min. Radii	Curve – with tangents Min. Radii
20	15m	10m
30	30m	20m
40	90m	40m
50	120m	60m
60	150m	80m

3.6 Crossfalls

- Crossfalls should be generally 3% either side of the crown
- One way crossfalls are acceptable in Access Place/Ways but around curves superelevation shall apply, with fall to the centre of the curve
- Cross falls may be varied at low points to ensure at least 0.5% gutter fall
- Crossfalls at intersections should be maintained on the priority road and adjusted on the minor road
- Crossfalls may be varied in the turning area of Access Place/Ways to allow for gutter outfall.
- Inverted crowns are prohibited in all roads except laneways.

3.7 Intersections

- Intersecting roads should be at right angles but not less than 70 degrees unless a roundabout treatment is applied.
- Opposing staggered intersections on a priority road should facilitate a left turn/right turn movement. Right turn/left turn movements are to be avoided.
- The minimum vehicle-turning path should be for a “design single unit truck”. (Min. 12m R)
- Kerbing shall be semi-mountable.
- Minimum kerb radii shall be:

Access Place/Way	12m
Local distributor	12m
District distributor and industrial	15m
- Sight distances are to comply with the “Austroads Design Guidelines”

3.8 Access Place/Way

- Turning circles should be 9m radius to the edge of the seal or be so configured to enable a “design single unit truck” to make a three point turn.
- Tapers at the turning circle should be 15m radius.
- Except at intersections kerbing shall be mountable conforming to the detail shown in fig. 2 below.

3.9 Roundabouts

- Design approach speed 60kph
- Ensure adequate deflection to maintain low traffic speeds on through movements
- Central island to be minimum of 5m radius
- Kerbing around the central island is to be mountable
- Annulus to be minimum 2.5m wide
- Provide for adequate night time visibility
- Ensure visibility over central island (low plantings etc for long-term visibility)
- Provide safe facilities for cyclists and pedestrians
- Hard and soft treatments to the central island are to be frangible.
- Irrigation conduits shall be placed prior to the final seal and shall be 100mm dia. Class A PVC with 600mm cover.

3.10 Laneways

- Cross section is to be designed such that the carriageway is hard against one boundary (opposite side to street light poles) and, opposite, the gap between the flush kerb and the other boundary is to be infilled with concrete to serve as a pedestrian refuge and protection for street lighting poles. (No bollard lights to be installed).
- The kerbing of the Access Place/Way is to be continued across the intersecting pavement of the Laneway

3.11 Footpaths

- Footpaths and Dual-use paths are to be provided as required under the “Liveable Neighbourhoods” guidelines.
- Footpaths and Dual-use paths may be built as part of the subdivision works or an agreed amount may be paid to Council who will then undertake the works when most of the housing is completed. (with preference being all paths to be bonded with the City for construction at a later date).
- Pram ramps are to be constructed as part of the kerbing works.
- Min width for all paths is 1.5m, and DUP’s 2.1m
- To minimise maintenance costs footpaths in road reserves will be of plain concrete with a broomed finish or coloured broomed finish plain concrete with easily obtainable colouring or a combination of either of the previous with a brick header course edging and a brick cross band every second expansion joint. Where coloured paving is required for consistency, colours to be similar and consistent with the adjoining development and approved separately by the City.

3.12 Street Name Plates

Street name plates be constructed using 200mm blades with 100mm or 150mm letters, coloured with blue letters on a reflective white background and, where practical, incorporating 50mm blue house numbers and Council’s Corporate Logo (as per City of Cockburn Specification Policy).

3.13 Street Lighting

- Street lighting including suitable illumination of traffic management treatments, to the newly created subdivision is to be provided in accordance with Western Power Corporation specification for illumination levels, materials and installation. Lighting design shall be in accordance with the latest edition of Australian Standards AS 1158-2005 and light pole types, colours and light fixtures to be similar and consistent with the adjoining development and approved separately by the City.
- Council is moving towards sustainable street lighting, the developer will therefore be encouraged to liaise with Western Power to use fluorescent street lighting, compact fluorescent (CFL) street lighting to reduce energy and green house gas emissions.
- Illumination is not to spill beyond the front building line of the adjacent properties unless required for security purposes.

3.14 “As Constructed” Information

The following “As Constructed” information, nominating the coordinate system used, is to be provided:

- A road and stormwater drainage layout plan, including footpaths, (if constructed) median islands etc., showing actual “as constructed” locations and levels on double matt polyester film marked and signed as such.

- A digital “As Constructed” copy on Australian MG94 Grid of the lot boundaries, road and stormwater drainage drawings in D-Spec and R-Spec format is to be supplied on disc or by e-mail. Alternatively, AutoCAD format is acceptable, but this is being phased out.
- A copy of all compaction tests results, including the asphalt and compliance certificates for the earthworks and road pavements are to be submitted.
- A Certificate of Compliance that the road and stormwater drainage infrastructure has been completed in accordance with the approved design drawings and specification is to be signed off by the developer’s project superintendent.

3.15 Standard Detail Design Drawings and Conditions

- The standard detail design drawings provided for download on the City of Cockburn’s website (click on Council Services, Engineering Services, then Engineering Guidelines) are to be used on all subdivisions design and constructed within the City of Cockburn
- Engineering conditions and accountabilities imposed on subdivision developments will be based on the template SUBDIVISION CONDITIONS TEMPLATE.

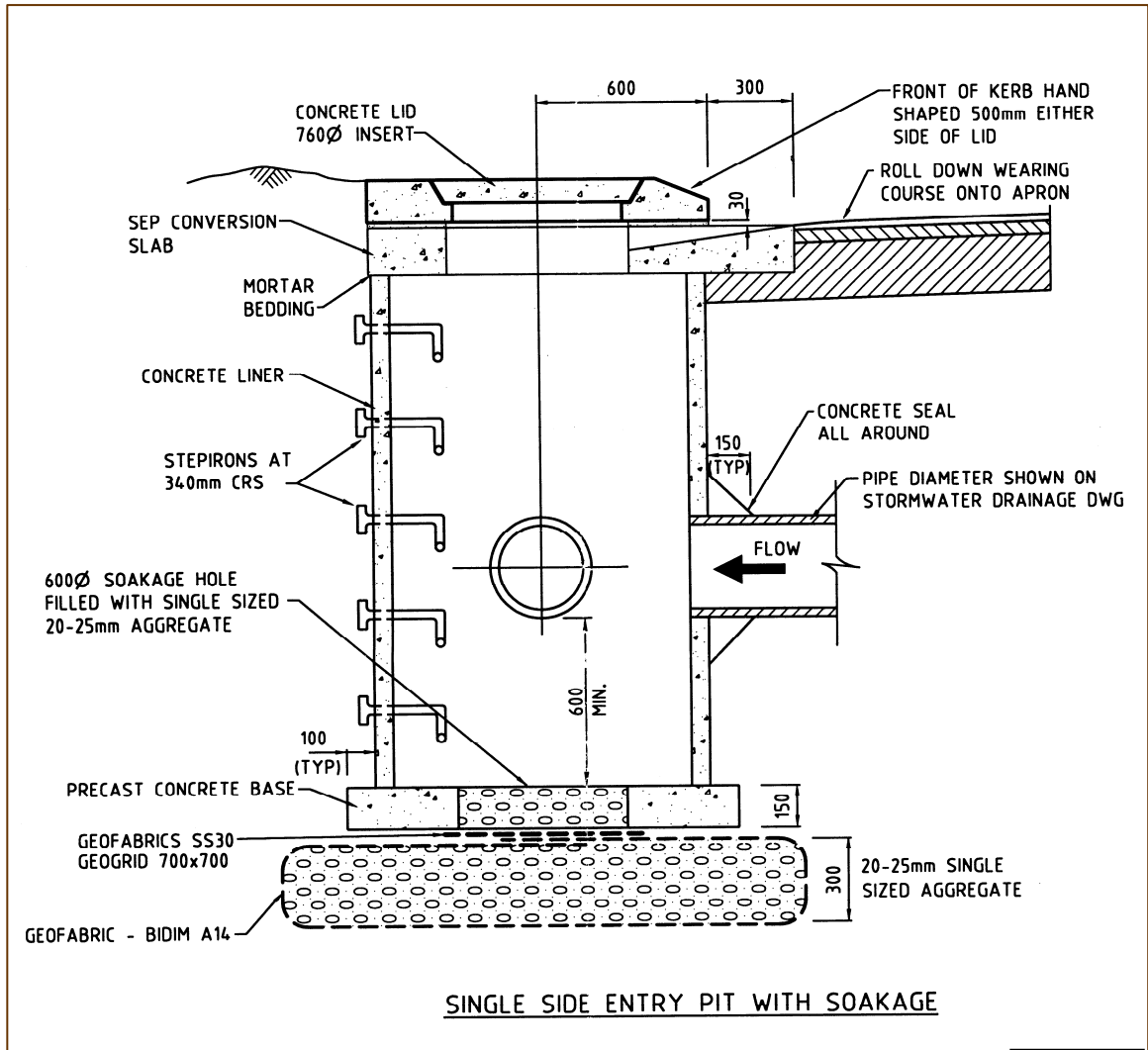

SINGLE SIDE ENTRY PIT WITH SOAKAGE

4.0 Public Open Space

4.1 Public Open Space Development Guidelines.

The City of Cockburn has introduced a separate set of guidelines for development of POS as follows;

- POS Development Guide,
- a three volume generic Irrigation Design Specification, and
- a sports pitch design specification document,

These are to be read in conjunction with this subdivision design guide.

These documents are available on the City's website at the following address;

http://www.cockburn.wa.gov.au/Council_Services/Engineering_Services/Subdivision_Engineering_Guidelines/default.asp

SUBDIVISIONS CONDITIONS TEMPLATE

Direct Telephone:
Our Ref: XXXXXXX

XXXXXX
XXXXXXXXXX
XXXXXXXXXXXX

Attention: XXXXXXX

Dear XXXXXXX

SUBDIVISION –

Your drawings numbered _____ incorporating the proposed road and stormwater drainage construction in the above development have been checked against Council's requirements, and have been accepted subject to any amendments, additions, etc., indicated in red on the drawings being incorporated into the works, and compliance with the following conditions.

General

1. It is a requirement of the Local Government Act under Section 295 that plans of the development is submitted to Council to allow conditions and amendments to be assigned.
2. All drawings associated with the development are to be certified by a practising chartered engineer. The development works are not to commence until these drawings have been received by the City of Cockburn and acknowledgment given by Council for the development works to proceed.
3. The approval to construct the work is provided on the basis that the design has been carried out by a qualified practising engineer and that engineer will ensure the works are carried out to the letter and intent of the drawings and the specification.

For this project, it is confirmed that _____ carried out the design and it is expected to be in accordance with Australian Standards and best engineering practice.

It is understood by the developers, owners of the land and the designers that no checking of the design has been undertaken by Council staff or its consultants.

As the maintenance of the drainage system will become the responsibility

of the City of Cockburn, it is important that the design engineer's supply any requirements that they know are essential in the maintenance programme so as not to compromise the integrity of their design.

4. The staff of the City of Cockburn cannot give on site approval to work that is not within proposed road reserve or drainage easements/reserves.

Construction Conditions

5. A joint inspection is to be carried out at the completion of each stage of the road and drainage construction and approval given prior to the commencement of subsequent stages. (Contact engineering services on 9411 3550).
6. Compaction tests on all stages of the pavement construction, including the asphalt, are to be taken by an independent NATA approved laboratory and the results submitted to Council.
7. All service crossings are to be placed under roads prior to the placing of the final seal.
8. All works on existing City infrastructure (roads, footpaths, drainage, parks or verges) are to be completed and reinstated in accordance with the "*Public Utilities Code of Practice 2000*", "*Restoration and Reinstatement Specification for Local Government 2002*" and the City of Cockburn "*Excavation Reinstatement Standards 2002*" as a minimum. The proponent is fully responsible for public liability and approved traffic management.
9. No existing roads are to be used for parking, fuelling or stockpiling of materials. Any damage caused to existing roads is to be made good prior to practical completion.
10. Sight distances and turning movements at all intersections are to be designed to relevant Australian Standards. This is especially required where traffic management devices have been placed.
11. Combination pits are to be installed at all "trapped" low points.
12. A hard copy of the "As Constructed" drawings of road and drainage works on double matt polyester film is to be provided at practical completion. In addition, an electronic "As Constructed" copy on Australian MG94 Grid of the lot boundaries, road and stormwater drainage drawings in D-Spec and R-Spec format is to be supplied on disc or by e-mail (shussain@cockburn.wa.gov.au). Alternatively, AutoCAD format is acceptable, but this is being phased out.
13. A set of plans is to be sent to Main Roads WA to allow the investigation into linemarking and relevant signage. Their address is:

Main Roads WA
Don Aitken Centre
Waterloo Crescent
EAST PERTH WA 6892
ATTENTION: Ian Edwards

14. Payment of engineering supervision fees of 1½% of contract price in accordance with Section 158(3)(b) of the Town Planning and Development Act 2005 to Council before clearance is requested.
15. Payment of a 2½% twelve-month maintenance bond on all works in the development appertaining to the Council before survey release.

In regard to Conditions 14 and 15 please advise the contract price of the works appertaining to Council so that engineering supervision fees and the maintenance bond can be assessed.

Environmental Conditions

16. No works are to commence until such time as:

A dust management plan in accordance with Council's Guidelines for the Preparation of Dust and Smoke Management Plans for the Development Sites within the City of Cockburn, and the Guidelines for the Prevention of Pollution from Land Development Sites in Western Australia published by the Department of Environmental Protection, July 1996, is approved by Council's Environmental Services Section.
17. No site works are to commence until a dust management plan complying with the City's policy is approved by the City's Health Services. The approved plan is to be implemented to its letter and intent. Failure to do so may result in a prosecution.
18. The works are to be carried out in such a manner that dust is controlled to prevent inconvenience.
19. All disturbed areas are to be stabilised to prevent sand drift prior to practical completion.
20. No activities are to be carried out after 6.00 pm or before 7.00 am Monday to Saturday and not at all on Sunday.

Private Property Conditions

21. Retaining walls are to be designed and certified by a practicing Structural Engineer and building licences are to be obtained for any proposed retaining walls to be constructed as part of the development.
22. The design engineer is to provide a certificate signed by a professional Geotechnical Engineer confirming that all completed earthworks are fit for their intended purpose. (i.e. site classification according to AS2870 – 1996).

Specific

23. The City of Cockburn requires, where practical, all service manholes to be removed from the road pavement, and the stormwater drainage design indicated is to be altered to reflect this.
24. The City of Cockburn standard detail drawings numbered 2423B03 – 01 to 16 are to apply. (Available on Council's web site).

http://www.cockburn.wa.gov.au/web/council_services/engineering/index.html

25. The attached Certificate of Compliance is to be completed and returned to this office at Practical Completion.
26. The developer shall provide street lighting including suitable illumination of traffic management treatments, to the newly created subdivision in accordance with Western Power Corporation specification for illumination levels, materials and installation. Lighting design shall be in accordance with the latest edition of Australian Standards AS 1158-2005 and light pole types, colours and light fixtures to be similar and consistent with the adjoining development and approved separately by the City. Please send a copy of the lighting design as soon as it becomes available.
27. Please refer a separate set of retaining wall drawings to Council's Principal Building Surveyor, Mr John West, for building license approval, prior to commencing works on the retaining walls.
28. Please provide details of MRWA approval of the linemarking / signs plan; please note that the linemarking and signage plan was not provided with the submission. Please also note that developers are responsible for all temporary signs/lines on roadways until MRWA signage and line markings are officially installed by MRWA's contractor
29. Please ensure that the selected contractor for these works reads your plans in conjunction with Council standard drawings (available on Council's web site). Please note Council has recently updated its pavement construction and kerbing profile standards. All pavements, kerbs and drainage structures should be as per Councils standards.

30. No sewer and drainage clash information was provided and also no sewer diagram was provided. Please ensure adequate coverage between sewer and drainage pipe exists.

The required modifications/comments are marked on the attached plans in red. Whilst the plans have been stamped with approval, works should not commence until those points raised above have been adequately addressed.

If you would like to discuss this matter further, please contact Council's Engineering Services on telephone 9411 3550.

Yours faithfully

Senior Development Engineer

Enc Plans
Certificate of Compliance

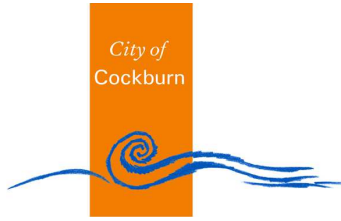

City of Cockburn Engineering Services

Certificate of Compliance

WAPC Ref No:..... **Location:**.....

Developer Name:.....

We, the undersigned, certify that the road and stormwater drainage infrastructure for the subdivision above have been completed in accordance with the approved design drawings and the specification.

Project Superintendent

Superintendents

Representative

Signature:..... Signature:.....

Name:..... Name:.....

Date:..... Date:.....

Company:..... Company:.....

The aforesaid works were undertaken by:

Contractor Roads

Company:.....

Address:.....

Contact person:.....

Phone No:

Contractor Stormwater Drainage

Company:.....Address:.....

Contact person:

Phone No: