

Bushfire Management Plan Coversheet

This Coversheet and accompanying Bushfire Management Plan has been prepared and issued by a person accredited by Fire Protection Association Australia under the Bushfire Planning and Design (BPAD) Accreditation Scheme.

Bushfire Management Plan and Site Details

Site Address / Plan Reference: Cockburn Central East Structure Plan

Suburb: Jandakot **State:** W.A. **P/code:** 6164

Local government area: City of Cockburn

Description of the planning proposal: New Structure Plan

BMP Plan / Reference Number: 180667 **Version:** 1.0 **Date of Issue:** 21/09/2018

Client / Business Name: City of Cockburn

Reason for referral to DFES

	Yes	No
Has the BAL been calculated by a method other than method 1 as outlined in AS3959 (tick no if AS3959 method 1 has been used to calculate the BAL)?	<input type="checkbox"/>	<input checked="" type="checkbox"/>
Have any of the bushfire protection criteria elements been addressed through the use of a performance principle (tick no if only acceptable solutions have been used to address all of the BPC elements)?	<input type="checkbox"/>	<input checked="" type="checkbox"/>
Is the proposal any of the following special development types (see SPP 3.7 for definitions)?		
Unavoidable development (in BAL-40 or BAL-FZ)	<input type="checkbox"/>	<input checked="" type="checkbox"/>
Strategic planning proposal (including rezoning applications)	<input checked="" type="checkbox"/>	<input type="checkbox"/>
Minor development (in BAL-40 or BAL-FZ)	<input type="checkbox"/>	<input checked="" type="checkbox"/>
High risk land-use	<input type="checkbox"/>	<input checked="" type="checkbox"/>
Vulnerable land-use	<input type="checkbox"/>	<input checked="" type="checkbox"/>

If the development is a special development type as listed above, explain why the proposal is considered to be one of the above listed classifications (E.g. considered vulnerable land-use as the development is for accommodation of the elderly, etc.)?

This Bushfire Management Plan is created to accompany a Local Structure Plan proposal.

Note: The decision maker (e.g. local government or the WAPC) should only refer the proposal to DFES for comment if one (or more) of the above answers are ticked "Yes".

BPAD Accredited Practitioner Details and Declaration

Name	Accreditation Level	Accreditation No.	Accreditation Expiry
Ian Macleod	2	BPAD39131	Nov 2019
Company		Contact No.	
Bushfire Prone Planning		6477 1144	

I declare that the information provided within this bushfire management plan is to the best of my knowledge true and correct

Signature of Practitioner



Date 21/09/2018



Bushfire Management Plan (Local Structure Planning)

Cockburn Central East Structure Plan - Jandakot

City of Cockburn

Job Number: 180667

Assessment Date: 29 August 2018

Report Date: 21 September 2018

BPP Group Pty Ltd t/a Bushfire Prone Planning

ABN: 39 166 551 784

Level, 159-161 James Street
Guildford WA 6055

PO Box 388
Guildford WA 6935

Ph: 08 6477 1144

Email: admin@bushfireprone.com.au



Commercial in Confidence

The information, including any intellectual property, contained in this document is confidential and proprietary to the Company. It may only be used by the person to whom it is provided for the stated purpose for which it is provided and must not be imparted to any third person without the prior written approval of the Company. The Company reserves all legal rights and remedies in respect of its confidential information.

Copyright ©2017 BPP Group Pty Ltd

All intellectual property rights, including copyright, in format and proprietary content contained in documents created by Bushfire Prone Planning, remain the property of BPP Group Pty Ltd. Any use made of such format or content without the prior written approval of Bushfire Prone Planning, will constitute an infringement on the rights of the Company which reserves all legal rights and remedies in respect of any such infringement.

Disclaimer

The measures contained in this Bushfire Management Plan are considered to be minimum standards and they do not guarantee that a building will not be damaged in a bushfire, persons injured, or fatalities occur either on the subject site or off the site while evacuating. This is substantially due to the unpredictable nature and behaviour of fire and extreme weather conditions. Additionally, the correct implementation of the required bushfire protection measures (and any associated response/evacuation plan if applicable) will depend, among other things, on the actions of the landowners or occupiers over which Bushfire Prone Planning has no control.

All surveys, forecasts, projections and recommendations made in this report associated with the project are made in good faith based on information available to Bushfire Prone Planning at the time.

All maps included herein are indicative in nature and are not to be used for accurate calculations.

Notwithstanding anything contained therein, Bushfire Prone Planning will not, except as the law may require, be liable for any loss or other consequences whether or not due to the negligence of their consultants, their servants or agents – arising out of the services provided by their consultants.

Document Control

Version	Version Details	Date Submitted
1.0	Original document	21-Sep-18
		-
		-

Author	Accreditation	Signature
--------	---------------	-----------

Ian Macleod

BPAD Level 2 - No. 39131



Co-author

Reviewed/Approved

Kathy Nastov

BPAD Level 3 - No. 27794



Document Content Compliance Statement

This Bushfire Management Plan (the Plan) provides the required information to address State Planning Policy No. 3.7: Planning in Bushfire Prone Areas - December 2015 (SPP 3.7), the associated Guidelines for Planning in Bushfire Prone Areas - WAPC 2017 v1.3 (Guidelines), and any additional information as directed by the WA Planning Commission (WA Department of Planning, Lands and Heritage). It is fit for accompanying a planning application.

Structure Plan / Subdivision BMP Template v7.3

Table of Contents

DOCUMENT CONTROL.....	1
EXECUTIVE SUMMARY.....	4
1 THE PROPOSAL AND PURPOSE OF THE PLAN	5
1.1 DETAILS	5
1.2 EXISTING DOCUMENTATION RELEVANT TO THE CONSTRUCTION OF THIS PLAN	9
2 ENVIRONMENTAL CONSIDERATIONS	10
2.1 NATIVE VEGETATION – MODIFICATION AND CLEARING	10
2.2 RE-VEGETATION / RETAINED VEGETATION / LANDSCAPE PLANS	13
3 POTENTIAL BUSHFIRE IMPACT ASSESSMENT	14
3.1 ASSESSMENT INPUT	14
3.1.1 Fire Danger Index (FDI) Applied.....	14
3.1.2 Existing Vegetation Identification, Classification and Effective Slope.....	14
3.2 ASSESSMENT OUTPUT	30
3.2.1 Indicative BAL Results Presented as a BAL Contour Map.....	31
3.2.2 Bushfire Attack Levels (BAL) Derived from The Contour Map.....	34
3.2.3 Issues Derived from The Contour Map.....	35
4 IDENTIFICATION OF BUSHFIRE HAZARD ISSUES	36
5 ASSESSMENT AGAINST THE BUSHFIRE PROTECTION CRITERIA (BPC)	38
5.1 BUSHFIRE PROTECTION CRITERIA - ASSESSMENT SUMMARY.....	38
5.2 LOCAL GOVERNMENT VARIATIONS TO APPLY.....	39
5.3 BUSHFIRE PROTECTION CRITERIA – ACCEPTABLE SOLUTIONS ASSESSMENT DETAIL	40
5.3.1 Element 1: Location	40
5.3.2 Element 2: Siting and Design of Development	41
5.3.3 Element 3: Vehicular Access	42
5.3.4 Element 4: Water.....	44
5.4 ADDITIONAL INFORMATION FOR REQUIRED BUSHFIRE PROTECTION MEASURES	45
5.4.1 Vegetation Management.....	45
5.4.2 Future Stage Planning Application – Additional Information Required	47
5.5 RECOMMENDED BUSHFIRE PROTECTION MEASURES	48
6 RESPONSIBILITIES FOR IMPLEMENTATION AND MANAGEMENT OF THE BUSHFIRE PROTECTION MEASURES.....	49
APPENDIX 1 - ONSITE VEGETATION MANAGEMENT TECHNICAL REQUIREMENTS.....	53
APPENDIX 2 - VEHICULAR ACCESS TECHNICAL REQUIREMENTS.....	58
APPENDIX 3 - WATER TECHNICAL REQUIREMENTS.....	62

List of Figures

FIGURE 1.1: PROPOSED STRUCTURE PLAN	6
FIGURE 1.2: PROPOSED STRUCTURE PLAN SPATIAL CONTEXT MAP.	7
FIGURE 1.3: SCREEN SHOT OF MAP OF BUSHFIRE PRONE AREAS FOR THE SUBJECT SITE AND SURROUNDS.....	8
FIGURE 3.1: VEGETATION CLASSIFICATION AND TOPOGRAPHY MAP.	29
FIGURE 3.2: BAL CONTOUR MAP.....	33
FIGURE 4.1: BUSHFIRE HAZARD LEVEL ASSESSMENT MAP.....	37

Executive Summary

This Bushfire Management Plan addresses the proposed Cockburn Central East Structure Plan. The Structure Plan is prepared to expedite planning requirements for new road alignments and to assist with the subdivision and development of lands within the structure plan extents.

The subject land is currently 60-70 percent developed with remnant areas of bushland in the western portion. A low lying wetland and drainage reserve exists in the eastern portion of the subject land on Cuttler Road. The area is generally used for industrial purposes. The Structure Plan area is bounded by industrial and residential lots to the north, east and south, and by the Kwinana Freeway to the west.

The Bushfire Hazard Level Assessment of the site demonstrates levels of low, moderate and extreme bushfire threat within and external to the subject land. However, this is considered manageable by compliance with the requirements of this Bushfire Management Plan.

A BAL-29 rating is achievable for future lots in this proposal dependent on lot layout and vegetation management within the Structure Plan extents. In some locations vegetation external to the Structure Plan area will affect BAL ratings and subdivision design (e.g. vegetation along abutting Kwinana Freeway reserve). Special attention should be taken when designing subdivisions abutting the two Park and Recreation Reserves to ensure that future lots can attain an acceptable BAL rating.

The structure plan design allows for multiple access/egress routes to the development, providing various choices of escape routes during a bushfire event. Three culs-de-sac currently exist within the Structure Plan area. These are located in low bushfire threat areas and have access to low bushfire threat escape routes.

Future developments will have a reticulated water supply with hydrants installed at the required intervals and to the required specifications.

1 The Proposal and Purpose of the Plan

1.1 Details

Proponent: City of Cockburn

Site Address: Multiple lots (See Figure 1.1)

Local Government: Local Government

Site Area: 108.28 hectares

No. of Proposed Lots: To be determined at a later planning stage

Planning Stage: Strategic - local structure plan

Overview of the Proposal:

The Cockburn Central East Structure Plan is prepared to expedite planning requirements for new road alignments and to assist with the subdivision and development of lands within the structure plan extents.



Bushfire Prone Planning
Commissioned to Produce the Plan by: The City of Cockburn

Purpose of the Plan: To support a strategic planning assessment

For Submission to: WA Planning Commission (WAPC)

Figure 1.1
Cockburn Central East
Structure Plan

LEGEND

-  Subject Area
-  Other Lots
-  Park & Recreation
-  Drainage
-  Light & Service Industry
-  Purposes
-  Mixed Business
-  Railway reserve

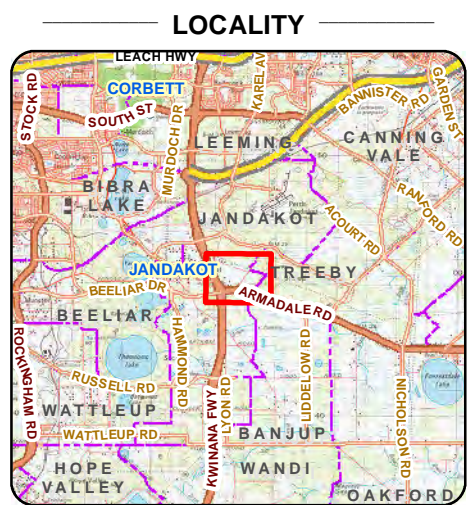
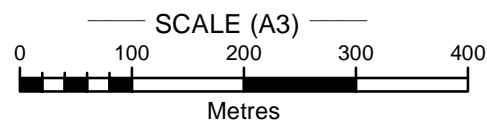

Aerial Imagery : Landgate/SLIP
Image Date : May/July 2018









Coordinate System: GDA 1994 MGA Zone 50
Projection: Universal Transverse Mercator Units: Metre

Map compiled by: Russell Wornes
Date map compiled/updated: 21/09/2018

Disclaimer and Limitation: This map has been prepared for bushfire management planning purposes only. All depicted areas, contours and any dimensions shown are subject to survey. Bushfire Prone Planning does not guarantee that this map is without flaw of any kind and disclaims all liability for any errors, loss or other consequence which may arise from relying on any information depicted.
Map Document Path / Name: G:\BushfireProneMapping\MXD's\2018\180667_Cockburn Central East Structure Plan_(A3L).mxd

Figure 1.2
Location Plan
(SPATIAL CONTEXT)

LEGEND

-  Subject Area
-  Other Lots
-  Locality / Suburb
-  Bush Forever
-  Regional Parks
-  Nature Reserve
-  Conservation Park
-  Crown Freehold - DBCA Managed

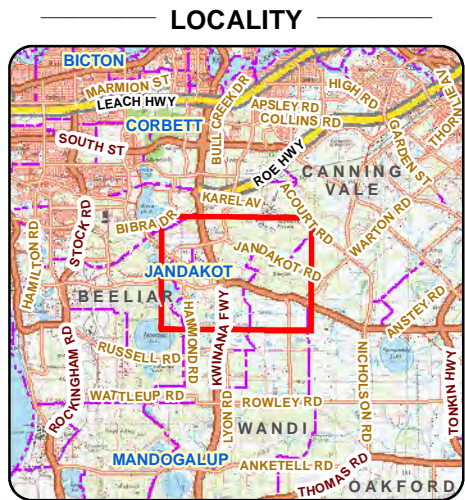
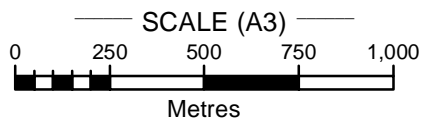

Aerial Imagery : Landgate/SLIP
Image Date : May/July 2018

Coordinate System: GDA 1994 MGA Zone 50
Projection: Universal Transverse Mercator Units: Metre



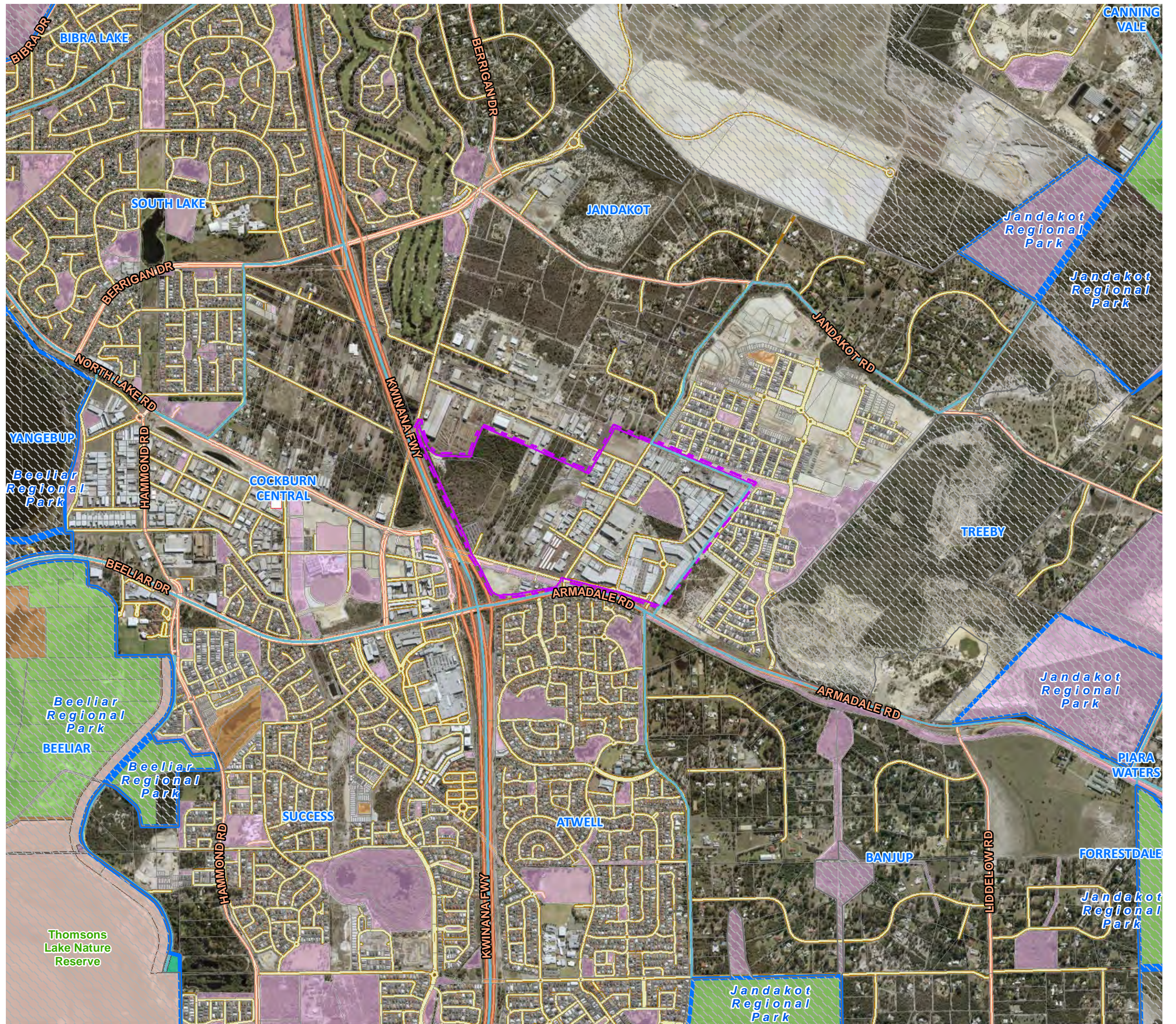

Map compiled by: Russell Wornes
Date map compiled/updated: 21/09/2018



Disclaimer and Limitation: This map has been prepared for bushfire management planning purposes only. All depicted areas, contours and any dimensions shown are subject to survey. Bushfire Prone Planning does not guarantee that this map is without flaw of any kind and disclaims all liability for any errors, loss or other consequence which may arise from relying on any information depicted.
Map Document Path / Name: G:\BushfireProneMapping\MXD\2018\180667_Cockburn Central East Structure Plan_(A3L).mxd

Figure 1.3
Bushfire Prone Area

LEGEND

-  Subject Area
-  Other Lots
-  Bushfire Prone Areas (2018)

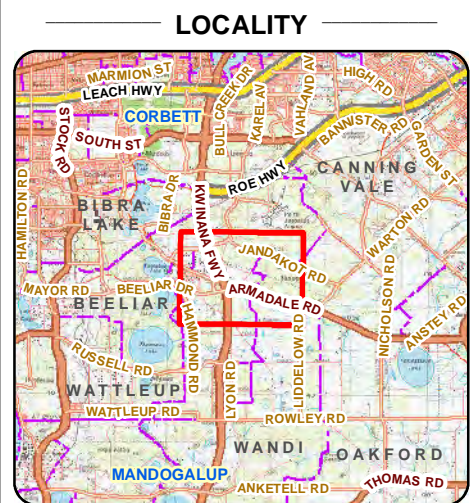
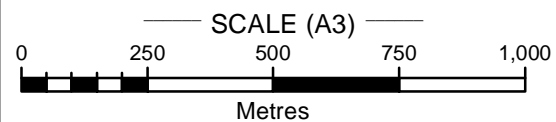

Aerial Imagery : Landgate/SLIP
Image Date : May/July 2018

Coordinate System: GDA 1994 MGA Zone 50
Projection: Universal Transverse Mercator Units: Metre



Map compiled by: Russell Wornes
Date map compiled/updated: 21/09/2018

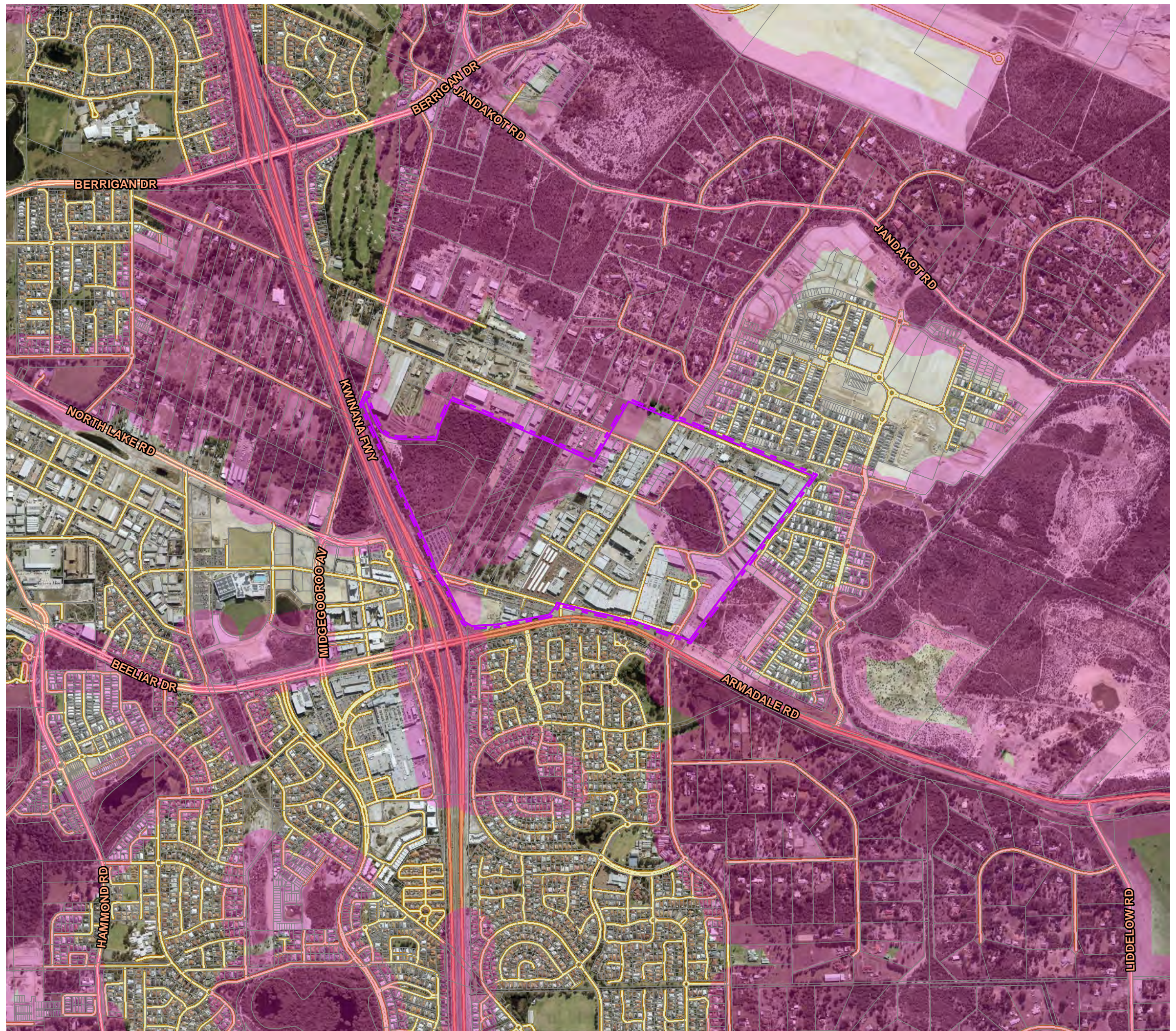

1.2 Existing Documentation Relevant to the Construction of this Plan

This section acknowledges any known reports or plans that have been prepared for previous planning stages, that refer to the subject area and that may or will impact upon the assessment of bushfire risk and/or the implementation of bushfire protection measures and will be referenced in this Bushfire Management Plan.

Relevant Documents		
Existing Document	Copy Provided by Client	Title
Structure Plan	Yes	Cockburn Central East Structure Plan
Environmental Report	Yes	Cockburn Central East Local Structure Plan (CCE LSP) Area, Level 1 Flora and Fauna Assessment
Landscaping (Revegetation) Plan	No	
Bushfire Risk Assessments	No	

2 Environmental Considerations

2.1 Native Vegetation – Modification and Clearing

‘Guidelines’ s2.3: “Many bushfire prone areas also have high biodiversity values. SPP 3.7 policy objective 5.4 recognises the need to consider bushfire risk management measures alongside environmental, biodiversity and conservation values.”

Existing conservation areas that are potentially affected by the development proposal are required to be identified. This may result in vegetation removal/modification prohibition or limitations. These areas include National Parks, Nature Reserves, Wetlands and Bush Forever sites.

Environmental Protection Act 1986: “Clearing of native vegetation in Western Australia requires a clearing permit under Part V, Division 2 of the Act unless clearing is for an exempt purpose. Exemptions from requiring a clearing permit are contained in Schedule 6 of the Act or are prescribed in the Environmental Protection Regulations” (‘Guidelines’ s2.3).

The Environmental Protection and Biodiversity Conservation Act 1999 (EPBC Act): This Act administered by the Australian Government Department of Environment, provides a national scheme of environment and heritage protection and biodiversity conservation. Nationally threatened species and ecological communities are a specific matter of significance. Areas of vegetation can be classified as a Threatened Ecological Community (TEC) under the EPBC Act and consequently have removal restrictions imposed.

Vegetation Modification and Clearing Assessment

Will on-site clearing of native vegetation be required?	Yes
Does this have the potential to trigger environmental impact/referral requirements under State and Federal environmental legislation?	Yes
Identified environmental legislation applicable to the Proposal site - No.1:	Threatened Ecological Communities (TEC)
Identified environmental legislation applicable to the Proposal site - No.2:	Conservation Category Wetlands and Buffer
For the proposed development site, have any areas of native vegetation been identified as species that might result in the classification of the area as a Threatened Ecological Community (TEC)?	Yes
Potential TEC species identified:	Banksia Woodlands of the Swan Coastal Plain

Within the subject land areas of Banksia woodland, a Threatened Ecological Community, exist. Low wetland areas also exist within the structure plan area, some of which are designated as ‘Parks and Recreation’.

The bushfire assessment and management strategies contained in the BMP, assume that environmental approval will be achieved or clearing permit exemptions will apply.

Recommendation: It is advised that the proponent refer to the “Cockburn Central East Local Structure Plan (CCE LSP) Area, Level 1 Flora and Fauna Assessment” or seek further advice from an Environmental Consultant or the WA Department of Parks and Wildlife for further information on the condition and species contained within the proposed development area and the requirement for referral of the proposal.

Development Design Options

Establishing development in bushfire prone areas can adversely affect the retention of native vegetation through clearing associated with the creation Lots and/or Asset Protection Zones. Where loss of vegetation is not acceptable or causes conflict with landscape or environmental objectives, it will be necessary to consider available design options to minimise the removal of native vegetation.

Minimising the Removal of Native Vegetation		
Design Option	Identified	Adopted
Reduction of lot yield	N/A	N/A
Cluster development	N/A	N/A
Construct building to a standard corresponding to a higher BAL rating as per BCA (AS 3959-2009 and/or NASH Standard)	N/A	N/A
Modify the development location	N/A	N/A

The proposed road layout will encroach partly into areas of wetland and Banksia woodland. However, the greater portion of these natural areas will remain intact.

Impact on Adjoining Land

Is this planning proposal able to implement the required bushfire measures within the boundaries of the land being developed so as not to impact on the bushfire and environmental management of neighbouring reserves, properties or conservation covenants?	Yes
---	-----

The Cockburn Central East Structure Plan area is approximately 60-70 percent developed and abuts existing developed areas. Further development within the structure plan area will reduce the impact of bushfire on neighbouring properties.

2.2 Re-vegetation / Retained Vegetation / Landscape Plans

Riparian zones, wetland/foreshore buffers, road verges and public open space may have plans to re-vegetate or retain vegetation as part of the Proposal.

Vegetation corridors may join offsite vegetation and provide a route for fire to enter a development area.

When applicable, any such area will be identified in this Bushfire Management Plan and their impact on the assessment and future management accounted for.

Is re-vegetation of riparian zones and/or wetland or foreshore buffers and/or public open space a part of this Proposal?	No
Is the requirement for ongoing maintenance of existing vegetation in riparian zones and/or wetland or foreshore buffers and/or public open space a part of this Proposal?	Yes

Two wetland areas will be set aside as Parks and Recreation areas and any future development plans should take into account the impact of these areas on neighbouring lots.

3 Potential Bushfire Impact Assessment

3.1 Assessment Input

3.1.1 Fire Danger Index (FDI) Applied

AS 3959-2009 specifies the fire danger index values to apply for different regions as per Table 2.1. The values used in the model calculations are for the Forest Fire Danger Index (FFDI) and for which equivalent representative values of the Grassland Fire Danger Index (GFDI) are applied as per Appendix B. The values can be refined if appropriately justified.

Table 3.1: Applied FDI Value

FDI Value			
Vegetation Area	As per AS 3959 - 2009 Table 2.1	As per DFES for the Location	Value Applied
All Areas	80	N/A	80

3.1.2 Existing Vegetation Identification, Classification and Effective Slope

Vegetation identification and classification has been conducted in accordance with AS 3959-2009 s2.2.3 and the Visual Guide for Bushfire Risk Assessment in WA (DoP February 2016).

When more than one vegetation type is present, each type is identified separately with the worst-case scenario being applied as the classification. The predominant vegetation is not necessarily the worst-case scenario.

The vegetation structure has been assessed as it will be in its mature state (rather than what might be observed on the day). Areas of modified vegetation are assessed as they will be in their natural unmodified state (unless maintained in a permanently low threat, minimal fuel condition, satisfying AS 3959-2009 s2.2.3.2-f and asset protection zone standards). Vegetation destroyed or damaged by a bushfire or other natural disaster has been assessed on its revegetated mature state.

Effective Slope: Is the ground slope under the classified vegetation and is determined for each area of classified vegetation. It is the measured or determined slope which will most significantly influence the bushfire behaviour in that vegetation as it approaches a building or site. Where there is a significant change in effective ground slope under an area of classified vegetation, that will cause a change in fire behaviour, separate vegetation areas will be identified, based on the change in effective slope, to enable the correct assessment.

Table 3.2: Vegetation identification and classification

All Vegetation Within 150 metres of the Proposed Development				
Vegetation Area	Identified Classification Types ¹ or Description if 'Excluded'	Applied Classification ²	Effective Slope Under Classified Vegetation	
			degrees	description
1	Woodland B-05	Class B Woodland	>0-5	Downslope
2	Tussock Grassland G-22 Sparse Open Tussock G-24	Class G Grassland	0	Flat
3	Tussock Grassland G-22	Class G Grassland	>0-5	Downslope
4	Open Heath C-11	Class C Shrubland	>0-5	Downslope
5	Open Scrub D-14	Class D Scrub	>15-20	Downslope
6	Open Scrub D-14	Class D Scrub	>10-15	Downslope
7	Open Scrub D-14	Class D Scrub	0	Upslope
8	Woodland B-05	Class B Woodland	0	Upslope
9	Open Forest A-03	Class A Forest	>0-5	Downslope
10	Open Heath C-11	Class C Shrubland	>0-5	Downslope
11	Closed Scrub D-13 Open Scrub D-14	Class D Scrub	>0-5	Downslope
-	Developed areas and managed gardens	Excluded AS3959-2009 2.2.3.2 (e) & (f)	N/A	N/A

Representative photos of each vegetation area, descriptions and classification justification, are presented on the following pages. The areas of classified vegetation are defined, and the photo locations identified on the topography and classified vegetation map, Figure 3.1.

Note¹: As per AS 3959-2009 Table 2.3 and Figures 2.3 and 2.4 a-g

Note²: As per AS 3959-2009 Table 2.3.

Vegetation Area 1

Classification Applied: Class B Woodland

Classification Justification: Banksia woodland with grass understorey, melaleuca wetland with grass understorey



Photo ID: 1a



Photo ID: 1b

Vegetation Area 1

Classification Applied: Class B Woodland

Classification Justification: Wetland, melaleuca, some wattle, banksia woodland, heath and grass



Photo ID: 1c



Photo ID: 1d

Vegetation Area 1

Classification Applied: Class B Woodland

Classification Justification: Eucalypts, some exotic species, shrubs, grass understorey



Photo ID: 1e



Photo ID: 1f

Vegetation Area 1

Classification Applied: Class B Woodland

Classification Justification: Eucalypts, grass understorey, some grass trees



Photo ID: 1g



Photo ID: 1h

Vegetation Area 1

Classification Applied: Class B Woodland

Classification Justification: Eucalypts with grass understorey



Photo ID: 1i

Vegetation Area 2

Classification Applied: Class G Grassland

Classification Justification: Vacant lots, tussock grasslands, vegetation assessed in mature state



Photo ID: 2a



Photo ID: 2b

Vegetation Area 2

Classification Applied: Class G Grassland

Classification Justification: Partly managed tussock grassland areas, occasional shrub or tree



Photo ID: 2c



Photo ID: 2d

Vegetation Area 3

Classification Applied: Class G Grassland

Classification Justification: Unmanaged tussock grassland, some areas of succulents



Photo ID: 3a



Photo ID: 3b

Vegetation Area 3

Classification Applied: Class G Grassland

Classification Justification: Tussock grassland, some areas of succulents, Drainage sump currently inundated



Photo ID: 3c



Photo ID: 3d

Vegetation Area 3

Classification Applied: Class G Grassland

Classification Justification: Partly managed tussock grassland area



Photo ID: 3e

Vegetation Area 4

Classification Applied: Class C Shrubland

Classification Justification: Area of grass trees with grassy understorey



Photo ID: 4a

Vegetation Area 5

Classification Applied: Class D Scrub

Classification Justification: Steep area of scrub planted along freeway reserve, grass understorey (Effective slope >15°-20°).



Photo ID: 5a

Vegetation Area 6

Classification Applied: Class D Scrub

Classification Justification: Areas of scrub planted along freeway reserve, grass understorey (Effective slope >10°-15°).



Photo ID: 6a



Photo ID: 6b

Vegetation Area 6

Classification Applied: Class D Scrub

Classification Justification: Areas of scrub planted along road reserve, grass understorey (Effective slope >10°-15°).



Photo ID: 6c

Vegetation Area 7

Classification Applied: Class D Scrub

Classification Justification: Areas of scrub planted along freeway reserve, grass understorey (Effective slope 0°).



Photo ID: 7a



Photo ID: 7b

Vegetation Area 7

Classification Applied: Class D Scrub

Classification Justification: Areas of scrub planted along freeway reserve (Effective slope 0°), Vacant lot, scrub, shrubs, grassy understorey

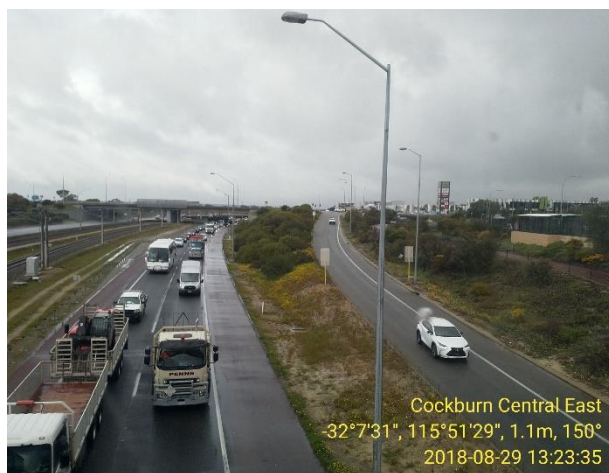

Photo ID: 7c



Photo ID: 7d

Vegetation Area 7

Classification Applied: Class D Scrub

Classification Justification: Vacant lot, scrub, shrubs, grassy understorey



Photo ID: 7e



Photo ID: 7f

Vegetation Area 8

Classification Applied: Class B Woodland

Classification Justification: Small area of eucalypts, scrub with grass understorey, assessed as woodland adopting precautionary principle



Photo ID: 8a



Photo ID: 8b

Vegetation Area 8

Classification Applied: Class B Woodland

Classification Justification: Small remnant sand dune populated with eucalypts, scrub and shrubs, grass understorey



Photo ID: 8c



Photo ID: 8d

Vegetation Area 9

Classification Applied: Class A Forest

Classification Justification: Wetland area, eucalypts, melaleuca, sheoak, scrub, shrubs



Photo ID: 9a



Photo ID: 9b

Vegetation Area 10

Classification Applied: Class C Shrubland

Classification Justification: Low lying wetland area, shrubs to 2 metres high



Photo ID: 10a

Vegetation Area 11

Classification Applied: Class D Scrub

Classification Justification: Areas of closed scrub and of regrowth, assessed in mature state



Photo ID: 11a



Photo ID: 11b

Vegetation Area

Classification Applied: Excluded AS3959-2009 2.2.3.2 (f)

Classification Justification: Managed lawns



Photo ID: 12a



Photo ID: 12b

Vegetation Area

Classification Applied: Excluded AS3959-2009 2.2.3.2 (f)

Classification Justification: Areas recently cleared of vegetation for development purposes



Photo ID: 12c



Photo ID: 12d

Vegetation Area

Classification Applied: Class B Woodland

Classification Justification: Managed drainage sump

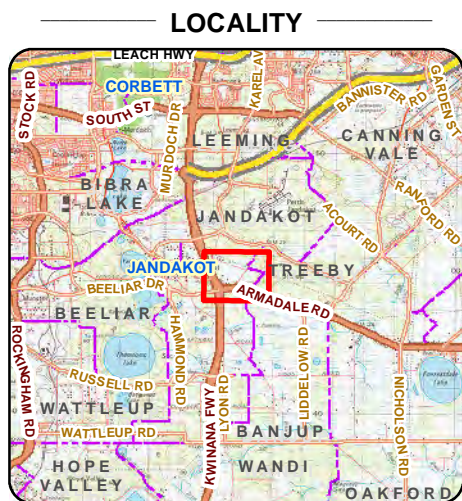
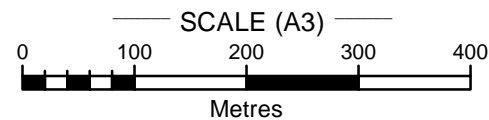

Photo ID: 12e

Figure 3.1
Topography & Classified Vegetation

LEGEND

- Subject Area
- Other Lots
- Assessment Area**
- Vegetation - 150m
- Classified Vegetation**
- Class (A) Forest
- Class (B) Woodland
- Class (C) Shrubland
- Class (D) Scrub
- Class (G) Grassland
- Exclusion 2.2.3.2
- Elevation contour (m)
- Photo no., location & direction



Aerial Imagery : Landgate/SLIP
Image Date : May/July 2018

Coordinate System: GDA 1994 MGA Zone 50
Projection: Universal Transverse Mercator Units: Metre



Map compiled by: Russell Wornes
Date map compiled/updated: 21/09/2018



Disclaimer and Limitation: This map has been prepared for bushfire management planning purposes only. All depicted areas, contours and any dimensions shown are subject to survey. Bushfire Prone Planning does not guarantee that this map is without flaw of any kind and disclaims all liability for any errors, loss or other consequence which may arise from relying on any information depicted.
Map Document Path / Name: G:\BushfireProneMapping\MXD's\2018\180667_Cockburn Central East Structure Plan_(A3L).mxd

3.2 Assessment Output

Understanding the Bushfire Assessment Results - Application of Bushfire Attack Levels (BAL)

The BAL rating has a different application in the building environment compared to the planning environment and the BAL assessment can result in a determined BAL or an indicative BAL which have different implications.

Building versus Planning Applications

In the building environment, a determined BAL rating is required (for the proposed construction) at the building application stage. This is to inform approval considerations and establish the construction standards that are to apply if approved. An indicative BAL rating is not acceptable for a building application.

In the planning environment, assessing the ability of a proposed development site to achieve BAL-29 or less is the objective (as one of the bushfire protection criteria being assessed). The 'development site' is defined by the LPS Amendment Regulations 2015 as "that part of a lot on which a building that is the subject of development stands or is to be constructed".

Therefore, being able to show that a BAL rating of BAL-29 or lower is achievable for a proposed development site (i.e. the building footprint) is an acceptable outcome for that criteria, as established by the bushfire provisions, SPP 3.7 and the associated Guidelines. For planning purposes, this BAL rating could be either indicative or determined.

Determined BAL Ratings

A determined BAL rating is to apply to an existing or proposed construction site (building) and not to a lot or envelope. Its purpose is to state the potential radiant heat flux to which the building will be exposed.

A determined BAL cannot be given for a future building whose location, elevation design and footprint (on a given lot) are unknown. It is not until these variables have been fixed that a BAL can be determined (typically at the development application or building application stage).

The one exception is when a building of **any dimension** can be **positioned anywhere** on a proposed lot or within defined limits within the lot (i.e. building setbacks or building envelope) and always remain subject to the same BAL rating. For this to be the case, there needs to be no classified vegetation either onsite or offsite that if retained could impact upon the determined BAL rating.

Indicative BAL Ratings

When this Plan presents a single indicative BAL rating for a proposed construction site (building), this will be because the construction is still subject to a location within the lot being confirmed and/or a vegetation separation distance being achieved. That is, it will be conditional upon some factor being confirmed at a later stage.

For planning applications associated with proposed lots, the building location, elevation design and footprint have typically not been established. Therefore, indicative rather than determined BAL rating/s will be presented for each lot (with the exception as noted above under 'Determined BAL Ratings').

When this Plan presents a single indicative BAL rating for a lot or building envelope (i.e. an 'area' that is not a located building footprint) it will represent the highest BAL rating affecting that 'area'. The BAL rating of a future building on that 'area' will be dependent on its eventual location.

Otherwise, this Plan will present all BAL ratings for each lot and for each BAL rating, the vegetation separation distances from each area of classified vegetation that are to apply. These distances will be presented as either figures in a table or as a BAL contour map.

From this indicative BAL information, it can be assessed if acceptable BAL ratings (\leq BAL-29) can be achieved for future buildings.

3.2.1 Indicative BAL Results Presented as a BAL Contour Map

Interpretation of the Bushfire Attack Level (BAL) Contour Map

The contour map will present different coloured contour intervals constructed around the classified bushfire prone vegetation. These represent the different Bushfire Attack Levels that exist at varying distances away from the classified vegetation.

Each BAL represents a set range of radiant heat flux (as defined by AS 3959-2009) that can be generated by the bushfire in that vegetation at that location.

The width of each shaded contour (i.e. the distance interval) will vary and is determined by consideration of variables including vegetation type, fuel structure, ground slope, climatic conditions. They are unique to a site and can vary across a site. The width of each contour is a diagrammatic expression of the separation distances from the classified vegetation that apply for each BAL rating, for that site.

A building (or 'area') located within any given BAL contour will be subject to that BAL rating and potentially multiple BAL ratings of which the highest rating will be applied.

Separation Distances Calculated to Construct the BAL Contours

Table 3.3: Vegetation separation distances applied to construct the BAL contours.

Vegetation Area	Vegetation Classification	Effective Slope	BAL Assessment Method Applied ¹	BAL Rating and Corresponding Separation Distance ² (metres)				
		Degrees		BAL-FZ	BAL-40	BAL-29	BAL-19	BAL12.5
1	Class B Woodland	>0-5	Method 1	<13	13-<17	17-<25	25-<35	35-<100
2	Class G Grassland	0	Method 1	<6	6-<8	8-<12	12-<17	17-<50
3	Class G Grassland	>0-5	Method 1	<7	7-<9	9-<14	14-<20	20-<50
4	Class C Shrubland	>0-5	Method 1	<7	7-<10	10-<15	15-<22	22-<100
5	Class D Scrub	>15-20	Method 1	<15	15-<21	21-<31	31-<43	43-<100
6	Class D Scrub	>10-15	Method 1	<14	14-<19	19-<28	28-<39	39-<100
7	Class D Scrub	0	Method 1	<10	10-<13	13-<19	19-<27	27-<100
8	Class B Woodland	0	Method 1	<10	10-<14	14-<20	20-<29	29-<100
9	Class A Forest	>0-5	Method 1	<20	20-<27	27-<37	37-<50	50-<100
10	Class C Shrubland	>0-5	Method 1	<7	7-<10	10-<15	15-<22	22-<100
11	Class D Scrub	>0-5	Method 1	<11	11-<15	15-<22	22-<31	31-<100
-	Excluded AS3959-2009 2.2.3.2 (e) & (f)	N/A	Method 1	N/A	N/A	N/A	N/A	N/A

¹Method 1 as per AS 3959-2009 Table 2.4.3.

Figure 3.2
BAL Contour Map

LEGEND

- Subject Area
- Other Lots
- Assessment Area**
- Vegetation - 150m
- BAL Contour - 100m
- Bushfire Attack Levels (Method 1)**
- Vegetation edge (Indicative only)
- BAL FZ (Indicative only)
- BAL 40 (Indicative only)
- BAL 29 (Indicative only)
- BAL 19 (Indicative only)
- BAL 12.5 (Indicative only)
- BAL LOW (Indicative only)

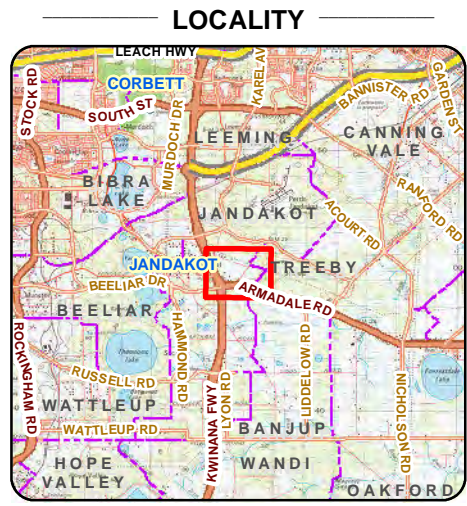
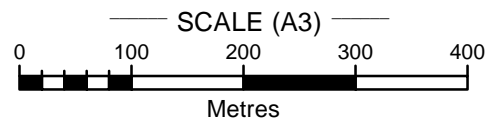

Aerial Imagery : Landgate/SLIP
Image Date : May/July 2018

Coordinate System: GDA 1994 MGA Zone 50
Projection: Universal Transverse Mercator Units: Metre

Map compiled by: Russell Wornes
Date map compiled/updated: 21/09/2018



Disclaimer and Limitation: This map has been prepared for bushfire management planning purposes only. All depicted areas, contours and any dimensions shown are subject to survey. Bushfire Prone Planning does not guarantee that this map is without flaw of any kind and disclaims all liability for any errors, loss or other consequence which may arise from relying on any information depicted.
Map Document Path / Name: G:\BushfireProneMapping\MXD\2018\180667_Cockburn Central East Structure Plan_(A3L).mxd

3.2.2 Bushfire Attack Levels (BAL) Derived from The Contour Map

Deriving a BAL Rating for a Future Construction Site (Building) from the BAL Contour Map Data (Capacity to Issue a BAL Certificate)

Key Assumptions: The actual location of a building within a lot or envelope (an 'area') has not been determined at this stage of planning; and the BAL ratings represent the BAL of an 'area' not a building.

The BAL Rating is Assessed as Indicative

If the assessed BAL for the 'area' is stated as being 'indicative', it is because that 'area' is impacted by more than one BAL contour interval and/or classifiable vegetation remains on the lot, or on adjacent lots, that can influence a future building's BAL rating (and this vegetation may have been omitted from being contoured for planning purposes e.g. Grassland or when the assumption is made that all onsite vegetation can be removed and/or modified).

In this report the indicative BAL is presented as either the highest BAL impacting the site or as a range of achievable BAL's within the site – whichever is the most appropriate.

The BAL rating that will apply to any future building within that 'area' will be dependent on:

1. vegetation management onsite; and/or
2. vegetation remaining on adjacent lots; and/or
3. the actual location of the future building within that 'area'.

A BAL Certificate cannot be provided for future buildings, within a lot or envelope with an indicative BAL, until the building location and in some instances building design (elevation), have been established and any required and approved vegetation modification/removal has been confirmed. Once this has occurred a report confirming the building location and BAL rating will be required to submit with the BAL certificate.

The required confirmation of the BAL rating must be done by a bushfire practitioner with the same level of accreditation as has been required to compile this Bushfire Management Plan. This is dependent on the type of calculations utilised (e.g. if performance based solutions have been used in the Plan BPAD Level 3 accreditation is required)

The BAL Rating is Assessed as Determined

If the assessed BAL for the lot or envelope is stated as being 'determined' it is because that lot or envelope is impacted by a single BAL contour interval. This BAL has been determined by the existence (or non-existence) of classified vegetation outside the lot or envelope, and no classifiable vegetation currently exists on the lot or envelope (i.e. it has been cleared to a minimal fuel, low bushfire threat state). In the situation where the BAL Contour Map has been constructed around multiple lots, there also needs to be no classifiable vegetation on an adjacent lot if this vegetation has not already been incorporated into the creation of the BAL Contour Map.

As a result, a determined BAL can be provided in this limited situation because:

1. No classified vegetation is required to be removed or modified to achieve the determined BAL, either within the lot/envelope or on adjacent lots (or if vegetation is excluded from classification, it is reasonable to assume it will be maintained in this state into the future); and
2. A future building can be located anywhere within the 'site' and be subject to the determined BAL rating; and
3. The degree of certainty is more than sufficient to allow for any small discrepancy that might occur in the mapping of the BAL contours.

For a determined BAL rating for a lot/envelope, A BAL Certificate (referring to this BMP) can be provided for a future building, if the BMP remains current.

3.2.3 Issues Derived from The Contour Map

The final lot layout for the proposed structure plan amendment is not known and therefore BAL ratings for future lots is not possible. However, the BAL Contour Map can be used as a planning tool for the design and location of future lots.

The BAL Contour Map assumes that all vegetation within the Cockburn Central East Structure Plan will be managed to a low bushfire threat state, with the exception of the two proposed Parks and Recreation areas.

Vegetation areas external to the structure plan boundaries are adopted and used in generating the BAL Contour Map. These areas of vegetation will affect subdivision design in their immediate vicinity. Some of these areas may be developed in the future.

Special attention should be taken when designing subdivisions abutting the two Park and Recreation Reserves to ensure that future lots can attain an acceptable BAL rating.

4 Identification of Bushfire Hazard Issues

The Bushfire Hazard Level Assessment of the site demonstrates levels of low, moderate and extreme bushfire threat within and external to the subject land. However, this is considered manageable by compliance with the requirements of this Bushfire Management Plan (See Figure 4.1 below).

Classified vegetation within and external to the Structure Plan area should be considered when designing future lot layouts to allow for compliance with the Bushfire Protection Criteria.

A bushfire hazard exists from the two proposed Park and Recreation areas and any undeveloped bush blocks within the structure plan extents. This should be considered when designing future subdivisions.

Areas surrounding the subject land are generally developed, with small sections of remnant vegetation on vacant lots and along the freeway reserve. A bushfire event within these vegetation areas will affect future lots in their vicinity.

Further away, some larger areas of undeveloped land exist to the north and east of the subject land. A wetland corridor running in a north-south direction is located approximately 2 kilometres west of the Structure plan area. Ember attack from a bushfire in these areas may impact the subject lots.

The structure plan design allows for multiple access/egress routes to the development, providing various choices of escape routes during a bushfire event. Three culs-de-sac currently exist within the Structure Plan area. These are located in low bushfire threat areas and have access to low bushfire threat escape routes.

Future developments will have a reticulated water supply with hydrants installed at the required intervals and to the required specifications.

5 Assessment Against the Bushfire Protection Criteria (BPC)

5.1 Bushfire Protection Criteria - Assessment Summary

Summarised Outcome of the Assessment Against the Bushfire Protection Criteria (BPC)				
Element	Basis for the Assessment of Achieving the Intent of the Element			
	Achieves compliance with the Element through meeting Acceptable Solutions		Achieves compliance with the Element by application of a Performance Based Solution	Minor or Unavoidable Development
	Meets all relevant acceptable solutions	One or more relevant Acceptable Solutions are not <u>fully</u> met. A <u>variation</u> of the solution is provided and justified.	One or more applicable Acceptable Solutions are not met. A solution is developed with the summary presented in this Plan in Section 5.5. The supporting document presenting Bushfire Prone Planning's detailed methodology is submitted separately to the decision makers.	The required supporting statements are presented in this Plan.
Location	✓			N/A
Siting and Design of Development	✓			
Vehicular Access	✓			
Water	✓			

The subject Proposal has been assessed against:

1. The requirements established in Appendix 4 of the Guidelines for Planning in Bushfire Prone Areas, WAPC 2017 v1.3 (the 'Guidelines'). The detail, including technical construction requirements, are found at <https://www.planning.wa.gov.au/8194.aspx>. A summary of relevant information is provided in the appendices of this Plan; and
2. Any endorsed variations to the Guideline's acceptable solutions and associated technical requirements that have been established by the relevant local government. If known and applicable these have been stated in Section 5.2 of this Plan with the detail included as an appendix if required by the relevant local government.

5.2 Local Government Variations to Apply

Local governments may add to or modify the acceptable solutions of the Bushfire Protection Criteria (BPC) and/or apply technical requirements that vary from those specified in the Guidelines for Planning in Bushfire Prone Areas (WAPC). In such instances, this Proposal will be assessed against these variations and/or any specific local government technical requirements for emergency access and water. Refer to Appendices 2 and 3 for relevant technical requirements.

Will local or regional variations to the acceptable solutions (endorsed by WAPC / DFES) and/or the technical requirements contained in the Guidelines, apply to this Proposal.	N/A
--	-----

5.3 Bushfire Protection Criteria – Acceptable Solutions Assessment Detail

5.3.1 Element 1: Location

Bushfire Protection Criteria Element 1: Location Assessment Statements and Bushfire Protection Measures to be Applied			
Intent: To ensure that strategic planning proposals, subdivision and development applications are located in areas with the least possible risk of bushfire to facilitate the protection of people, property and infrastructure.			
Acceptable Solution:	A1.1: Development Location	Method of achieving Element compliance and/or the Intent of the Element:	The acceptable solution can be fully met in the future (at a later planning stage).

The proposed structure plan achieves compliance by:

- By ensuring future building work on the lots can be located on an area that will be subject to potential radiant heat from a bushfire not exceeding 29 kW/m² (i.e. a BAL rating of BAL-29 or less will apply). This can be achieved by using positioning, design and appropriate vegetation removal/modification; and
- Managing the remaining bushfire risk to an acceptable level by the existence/implementation and ongoing maintenance of all required bushfire protection measures, as identified within this Plan. These measures include the requirements for vegetation management, vehicular access and firefighting water supply.

5.3.2 Element 2: Siting and Design of Development

Bushfire Protection Criteria Element 2: Siting and Design of Development

Assessment Statements and Bushfire Protection Measures to be Applied

Intent: To ensure that the siting and design of development (note: not building/construction design) minimises the level of bushfire impact.

Acceptable Solution:	A2.1: Asset Protection Zone	Method of achieving Element compliance and/or the Intent of the Element:	The acceptable solution can be fully met in the future (at a later planning stage).
----------------------	-----------------------------	--	---

The proposed Structure Plan achieves compliance by:

- Ensuring building work on the future lots can have established around it an APZ of the required dimensions - to ensure that the potential radiant heat from a bushfire to impact future buildings, does not exceed 29 kW/m² (i.e. a BAL rating of BAL-29 or less will apply to determine building construction standards);
- The APZs can be partially established within each lots boundaries. The balance of the APZ's required dimensions are being contributed by an area on adjoining land that is either non-vegetated or assessed as being managed in a low-fuel state and which can most reasonably be expected to be managed this way in perpetuity.
- The landowners having the responsibility of continuing to manage the required APZ as low threat vegetation in a minimal fuel state, by maintaining the APZ to the required dimensions and standard, including compliance with the local government's annual firebreak notice.

The required APZ dimensions are set out in Section 5.4.1. The APZ technical requirements (Standards) are detailed in Appendix 1.

5.3.3 Element 3: Vehicular Access

Bushfire Protection Criteria Element 3: Vehicular Access
Assessment Statements and Bushfire Protection Measures to be Applied

Intent: To ensure that the vehicular access serving a subdivision/development is available and safe during a bushfire event.

Acceptable Solution:	A3.1: Two access routes	Method of achieving Element compliance and/or the Intent of the Element:	The acceptable solution can be fully met in the future (at a later planning stage).
----------------------	----------------------------	--	---

All future roads on the proposed Structure Plan provide safe access and egress to two different destinations. As sealed public roads, they will be available to all residents and the public at all times and under all weather conditions.

Monash Gate, Dollier Street and Avior Avenue are existing culs-de-sac in a built up area. Each of these roads are in, and can exit onto, low bushfire threat areas providing a safe escape route.

All future roads within the structure plan area should be designed to provide safe access and egress during a bushfire event.

Acceptable Solution:	A3.2 Public Road	Method of achieving Element compliance and/or the Intent of the Element:	The acceptable solution can be fully met in the future (at a later planning stage).
----------------------	---------------------	--	---

All future roads within the structure plan area should be designed to provide safe access and egress during a bushfire event.

The construction technical requirements established by the Guidelines and/or the local government can and will be complied with. These requirements are set out in Appendix 2.

Bushfire Protection Criteria Element 3: Vehicular Access (continued)

Assessment Statements and Bushfire Protection Measures to be Applied

Acceptable Solution:	A3.3 Cul-de-sacs (including a dead-end road)	Method of achieving Element compliance and/or the Intent of the Element:	The acceptable solution can be fully met in the future (at a later planning stage).
----------------------	--	--	---

Culs-de sac should be avoided where possible.

Monash Gate, Dollier Street and Avior Avenue are existing culs-de-sac in a built up area. Each of these roads are in, and can exit onto, low bushfire threat areas providing a safe escape route.

The construction technical requirements established by the Guidelines and/or the local government can and will be complied with. These requirements are set out in Appendix 2.

Acceptable Solution:	A3.4: Battle-axe	Method of achieving Element compliance and/or the Intent of the Element:	The acceptable solution can be fully met in the future (at a later planning stage).
----------------------	------------------	--	---

Battle-axe lots should be avoided where possible.

The construction technical requirements established by the Guidelines and/or the local government can and will be complied with. These requirements are set out in Appendix 2.

Acceptable Solution:	A3.5: Private Driveways	Method of achieving Element compliance and/or the Intent of the Element:	The acceptable solution can be fully met in the future (at a later planning stage).
----------------------	-------------------------	--	---

The construction technical requirements established by the Guidelines and/or the local government can and will be complied with. These requirements are set out in Appendix 2.

Acceptable Solution:	A3.6 Emergency Access Way	Method of achieving Element compliance and/or the Intent of the Element:	N/A
----------------------	------------------------------	--	-----

No emergency access ways are currently designed for this structure plan.

Acceptable Solution:	A3.7 Fire Service Access Routes	Method of achieving Element compliance and/or the Intent of the Element:	N/A
----------------------	------------------------------------	--	-----

No fire service access routes are currently designed for this structure plan.

Acceptable Solution:	A3.8 Firebreak Width	Method of achieving Element compliance and/or the Intent of the Element:	The acceptable solution can be fully met in the future (at a later planning stage).
----------------------	-------------------------	--	---

The proposed lots will comply with the requirements of the local government annual firebreak notice issued under s33 of the Bush Fires Act 1954.

5.3.4 Element 4: Water

Bushfire Protection Criteria Element 4: Water
Assessment Statements and Bushfire Protection Measures to be Applied

Intent: To ensure water is available to the subdivision, development or land use to enable people, property and infrastructure to be defended from bushfire.

Acceptable Solution:	A4.1 Reticulated Areas	Method of achieving Element compliance and/or the Intent of the Element:	The acceptable solution can be fully met in the future (at a later planning stage).
----------------------	------------------------	--	---

A reticulated water supply is available to the subject site and hydrants will be installed in locations as required. (Required hydrant separation distances – 100m commercial, 200m residential, 400m).

Multiple hydrants currently exist within the Structure Plan area.

The construction technical requirements established by the Guidelines and/or the local government can and will be complied with. These requirements are set out in Appendix 3.

Acceptable Solution:	A4.2 Non-Reticulated Areas	Method of achieving Element compliance and/or the Intent of the Element:	N/A
Acceptable Solution:	A4.3 Non-reticulated Areas (Individual Lots)	Method of achieving Element compliance and/or the Intent of the Element:	N/A

5.4 Additional Information for Required Bushfire Protection Measures

The purpose of this section of the Plan is:

- As necessary, to provide additional detail (to that provided in the tables of Section 5.3) regarding the implementation of the acceptable solutions for those persons who will have the responsibility to apply the stated requirements;
- As necessary, to detail specific onsite vegetation management requirements such as the APZ dimensions, management of Public Open Space or application of landscaping plans for onsite vegetation;
- To discuss how staged development will be handled, if applicable; and
- As relevant, for future planning stages, consider and discuss the requirements that may apply to future planning applications and the content of the associated BMP. In particular:
 - Any potential Vulnerable or High-Risk Land Uses.
 - Any additional content that will be required in the future BMP.

5.4.1 Vegetation Management

Asset Protection Zone (APZ) Dimensions that are to Apply

The required dimensions of the APZ will vary dependent upon the purpose for which the APZ has been defined. There are effectively three APZ dimensions that can apply:

1. An application for planning approval will be required to show that an APZ can be created which is of sufficient size to ensure the potential radiant heat impact of a fire does not exceed 29kW/m^2 (BAL-29); and
2. If the assessment has determined a BAL rating for an existing or future building is less than BAL-29, the APZ must be of sufficient size to ensure the potential radiant heat impact of a fire does not exceed the kW/m^2 corresponding to the lower assessed BAL rating; or
3. Complying with the relevant local government's annual firebreak notice may require an APZ of greater size than that defined by the two previous parameters.

The dimensions (vegetation separation distances) that are to apply to the APZ for this Proposal are presented in the tables below.

The 'Planning (WAPC) BAL-29' APZ				
Required Dimensions for the Subject Site				
Requirement Set By	Guidelines for Planning in Bushfire Prone Areas (WAPC 2017 v1.3)			
Relevant Fire Danger Index (AS3959-2009 Table 2.1)	80			
BAL Determination Method	Method 1 (as per AS 3959-2009 s2.2.6 and Table 2.4.3)			
Vegetation Area	Applied Vegetation Classification	Effective Slope (degrees)	Maximum Acceptable 'Planning' BAL	Required Separation Distance (metres)
1	Class B Woodland	>0-5	BAL-29	17
2	Class G Grassland	0		8
3	Class G Grassland	>0-5		9
4	Class C Shrubland	>0-5		10
5	Class D Scrub	>15-20		21
6	Class D Scrub	>10-15		19
7	Class D Scrub	0		13
8	Class B Woodland	0		14
9	Class A Forest	>0-5		27
10	Class C Shrubland	>0-5		10
11	Class D Scrub	>0-5		15
	Excluded AS3959-2009 2.2.3.2 (e) & (f)	N/A		N/A
This requirement has been established through the State bushfire provisions, SPP 3.7 and the associated Guidelines, as being a key compliance requirement for development proposals in WA.				

'Local Government Firebreak Notice APZ'	
Required Minimum Dimensions for the Subject Site	
Requirement Set By:	City of Cockburn
Minimum Dimensions:	See City of Cockburn Fire Control Order
Other Conditions:	If Asset Protection Zone technical requirements are defined in the Notice, the standards and dimensions may differ from the Guideline's APZ Standards, with the intent to better satisfy local conditions. When these are more stringent than those created by the Guidelines, or less stringent and endorsed by the WAPC and DFES, they must be complied with. Refer to Appendix 1.
This requirement has been established through the stated local government's annual fire break notice issued under the Bushfires Act 1954 s33.	

Consideration/Implementation of Public Open Space Management

Two areas of Public Open Space exist within the Structure Plan boundaries. Both these are wetland areas which provide habitats for ground dwelling mammals and reptiles and are to be maintained in their current natural state.

Future subdivision design should provide for required separation distances from this vegetation.

Consideration/Implementation of Staged Development

Where the development is to be staged, additional land management external to the stage may be required to achieve acceptable BAL ratings for proposed lots.

5.4.2 Future Stage Planning Application – Additional Information Required

Future planning applications such as subdivision applications will be required to demonstrate how the Bushfire Protection Criteria are to be complied with. That is, each future lot must demonstrate that a future building on that lot can achieve BAL-29 or lower construction standards. The design of a subdivision must also minimise the level of impact from a bushfire by strategic road design, lot layout and water supply as described in the Guidelines for Planning in Bushfire Prone Areas.

5.5 Recommended Bushfire Protection Measures

These recommendations are for measures that are not directly considered by SPP 3.7 and the associated Guidelines, including the bushfire protection criteria.

These measures are recommended by the bushfire consultant to improve the safety of property occupants and the resilience of buildings in the event of a bushfire impacting the property.

Recommendations may be of specific benefit in supporting applications for 'Minor Development' or 'Unavoidable Development' which are otherwise unable to fully comply with the established bushfire protection criteria.

Retrospective Application of Bushfire Construction Standards

Class 1, 2 and 3 buildings and Class 10a associated buildings and decks, constructed prior to the requirement to comply with bushfire performance requirements, do not need to meet these requirements.

Buildings of Class 4 to Class 9 are not required by the Building Code of Australia (BCA) to be constructed to comply with bushfire performance requirements. Although responsible authorities may require it.

Retrospectively upgrading buildings to assist in reducing bushfire risk to persons and property is a voluntary choice.

Where existing buildings are located in a bushfire prone area and may be subject to a bushfire attack, Bushfire Prone Planning recommends that some degree of upgrading be considered to improve the protection for occupants and the building's survivability. At a minimum protection from ember attack should be considered (i.e. constructed to the standard required for BAL-12.5).

6 Responsibilities for Implementation and Management of the Bushfire Protection Measures

Table 6.1: BMP Implementation responsibilities prior to the issue of titles for the Developer (Landowner).

DEVELOPER (LANDOWNER) - PRIOR TO ISSUE OF TITLES		
No.	Implementation Actions	Subdivision Clearance
1	<p>Planning approval may be conditioned with the requirement to make appropriate notifications (on the certificates of title and the deposited plan), of the existence of this Bushfire Management Plan.</p> <p>The WAPC may condition a subdivision application approval with a requirement for the landowner / proponent to place a notification onto the certificate(s) of title and a notice of the notification onto the diagram or plan of survey (deposited plan). This will be done pursuant to Section 165 of the Planning and Development Act 2005 ('Hazard etc. affecting land, notating titles as to:') and applies to lots with a determined BAL rating of BAL-12.5 or above. The notification will be required to state:</p> <p><i>'This land is within a bushfire prone area as designated by an Order made by the Fire and Emergency Services Commissioner and may be subject to a Bushfire Management Plan. Additional planning and building requirements may apply to development on this land'.</i></p>	<input type="checkbox"/>
2	Construct the public roads and cul-de-sacs to the standards stated in the BMP.	<input type="checkbox"/>
3	Construct the private driveways and battle axes to the standards stated in the BMP.	<input type="checkbox"/>
4	Install the reticulated water supply (hydrants) to the standards stated in the BMP.	<input type="checkbox"/>

Table 6.2: BMP Implementation responsibilities prior to lot sale, occupancy or building for the Landowner (Developer).

LANDOWNER (DEVELOPER) - PRIOR TO LOT SALE, OCCUPANCY OR BUILDING	
No.	Implementation Actions
1	Prior to sale and post planning approval, the entity responsible for having the BMP prepared should ensure that anyone listed as having responsibility under the Plan has endorsed it and is provided with a copy for their information and informed that it contains their responsibilities. This includes the landowners/proponents (including future landowners where the Plan was prepared as part of a subdivision approval), local government and any other authorities or referral agencies ('Guidelines' s4.6.3).
2	Prior to sale of the future lots, each individual lot is to be compliant with the relevant local government's annual firebreak notice issued under s33 of the Bushfires Act 1954.
3	Establish the Asset Protection Zone (APZ) on the lot to the dimensions and standard stated in the BMP. This is the responsibility of the developer.
4	<p>Prior to any building work, inform the builder of the existence of this Bushfire Management Plan and the responsibilities it contains, regarding the required construction standards. This will be:</p> <ul style="list-style-type: none"> • The standard corresponding to the determined BAL rating, as per the bushfire provisions of the Building Code of Australia (BCA); and/or • A higher standard as a result of the BMP establishing that construction is required at a standard corresponding to a higher BAL rating.

Table 6.3: Ongoing management responsibilities for the Landowner/Occupier.

LANDOWNER/OCCUPIER - ONGOING	
No.	Ongoing Management Actions
1	Maintain the Asset Protection Zone (APZ) to the dimensions and standard stated in the BMP
2	Comply with the City of Cockburn Fire Control Order issued under s33 of the Bush Fires Act 1954.
3	Maintain vehicular access routes within the lots to the required surface condition and clearances as stated in the BMP.
4	Maintain the emergency water supply tank and its associated fittings and vehicular access in good working condition.
5	Ensure that any builders (of future structures on the lot) are aware of the existence of this Bushfire Management Plan and the responsibilities it contains regarding the application of construction standards corresponding to a determined BAL rating.
6	<p>Ensure all future buildings the landowner has responsibility for, are designed and constructed in full compliance with:</p> <ol style="list-style-type: none"> 1. the requirements of the WA Building Act 2011 and the bushfire provisions of the Building Code of Australia (BCA); and 2. with any identified additional requirements established by this BMP or the relevant local government.

Table 6.4: Ongoing management responsibilities for the Local Government.

LOCAL GOVERNMENT - ONGOING	
No.	Ongoing Management Actions
1	Monitor landowner compliance with the Bushfire Management Plan and the annual City of Cockburn Fire Control Order.
2	Any future reserves, with the exclusion of those 2 currently marked on the Cockburn Central East Structure Plan, to be managed to ensure the vegetation remains as low threat vegetation, in accordance with AS3959-2009.
	Where control of an area of vegetated land is vested in the control of the local government and that area of land has influenced the assessed BAL rating/s of the subject site/s – and the BAL rating has been correctly assessed - there is an obligation to consider the impact of any changes to future vegetation management and/or revegetation plans with respect to that area.

Appendix 1 - Onsite Vegetation Management Technical Requirements

It is the responsibility of the landowner to maintain the established bushfire protection measures on their property. Not complying with these responsibilities can result in buildings being subject to a greater potential impact from bushfire than that determined by the assessed BAL rating presented in this Bushfire Management Plan.

For the management of vegetation within a lot (i.e. onsite) the following technical requirements exist:

1. **The APZ:** Installing and maintaining an asset protection zone (APZ) of the required dimensions to the standard established by the Guidelines for Planning in Bushfire Prone Areas (WA Planning Commission, as amended). When, due to the planning stage of the proposal to which this Bushfire Management Plan applies, defined APZ dimensions are known and are to be applied to existing or future buildings – then these dimensions are stated in Section 5.4.1 of this Plan.
2. **The Firebreak/Fuel Load Notice:** Complying with the requirements established by the relevant local government's annual firebreak notice issued under s33 of the Bushfires Act 1954. Note: If an APZ requirement is included in the Notice, the standards and dimensions may differ from the Guideline's APZ Standard – the larger dimension must be complied with.
3. **Changes to Vegetated/Non-Vegetated Areas:**
 - a. If applicable to this Plan, the minimum separation distance from any classified vegetation, that corresponds to the determined BAL for a proposed building, must be maintained as either a non-vegetated area or as low threat vegetation managed to a minimal fuel condition as per AS 3959-2009 s2.2.3.2 (e) and (f). Refer to Part 4 of this Appendix 1.
 - b. Must not alter the composition of onsite areas of classified vegetation (as assessed and presented in Section 3.1.2) to the extent that would require their classification to be changed to a higher bushfire threat classification (as per AS 3959-2009); and
 - c. Must not allow areas within a lot (i.e. onsite) that have been:
 - i. excluded from classification by being low threat vegetation or non-vegetated; and
 - ii. form part of the assessed separation distance that is determining a BAL rating -
...to become vegetated to the extent they no longer represent a low threat (refer to Part 4 of Appendix 1). Note: The vegetation classification exclusion specifications as established by AS 3959-2009 s2.2.3.2, are included at A1.4 below for reference.

1. Requirements Established by the Guidelines – the Asset Protection Zone (APZ) Standards

(Source: Guidelines for Planning in Bushfire Prone Areas - WAPC 2017 v1.3 Appendix 4, Element 2, Schedule 1 and Explanatory Note E2.1)

Defining the Asset Protection Zone (APZ)

Description: An APZ is an area surrounding a building that is managed to reduce the bushfire hazard to an acceptable level (by reducing fuel loads). The width of the required APZ varies with slope and vegetation. For planning applications, the minimum sized acceptable APZ is that which is of sufficient size to ensure the potential radiant heat impact of a fire does not exceed 29kW/m² (BAL-29). It will be site specific.

The APZ may include public roads, waterways, footpaths, buildings, rocky outcrops, golf courses, maintained parkland as well as cultivated gardens in an urban context, but does not include grassland or vegetation on a neighbouring rural lot, farmland, wetland reserves and unmanaged public reserves.

For subdivision planning, design elements and excluded/low threat vegetation adjacent to the lot can be utilised to achieve the required vegetation separation distances and therefore reduce the required dimensions of the APZ within the lot.

Defendable Space: The APZ includes a defendable space which is an area adjoining the asset within which firefighting operations can be undertaken to defend the structure. Vegetation within the defendable space should be kept at an absolute minimum and the area should be free from combustible items and obstructions. The width of the defendable space is dependent on the space which is available on the property, but as a minimum should be 3 metres.

Establishment: The APZ should be contained solely within the boundaries of the lot on which the building is situated, except in instances where the neighbouring lot or lots will be managed in a low-fuel state on an ongoing basis, in perpetuity.

Note: Regardless of whether an Asset Protection Zone exists in accordance with the acceptable solutions and is appropriately maintained, fire fighters are not obliged to protect an asset if they think the separation distance between the dwelling and vegetation that can be involved in a bushfire, is unsafe.

Schedule 1: Standards for APZ

Fences: within the APZ are constructed from non-combustible materials (e.g. iron, brick, limestone, metal post and wire). It is recommended that solid or slatted non-combustible perimeter fences are used.

Objects: within 10 metres of a building, combustible objects must not be located close to the vulnerable parts of the building i.e. windows and doors.

Fine Fuel Load: combustible dead vegetation matter less than 6 mm in thickness reduced to and maintained at an average of two tonnes per hectare (example below).

Example Fine Fuel Load of Two Tonnes per Hectare



(Image source: Shire of Augusta Margaret River’s Firebreak and Fuel Reduction Hazard Notice)

Trees (> 5 metres in height): trunks at maturity should be a minimum distance of 6 metres from all elevations of the building, branches at maturity should not touch or overhang the building, lower branches should be removed to a height of 2 metres above the ground and or surface vegetation, canopy cover should be less than 15% with tree canopies at maturity well spread to at least 5 metres apart as to not form a continuous canopy. Diagram below represents tree canopy cover at maturity.

Tree canopy cover – ranging from 15 to 70 per cent at maturity

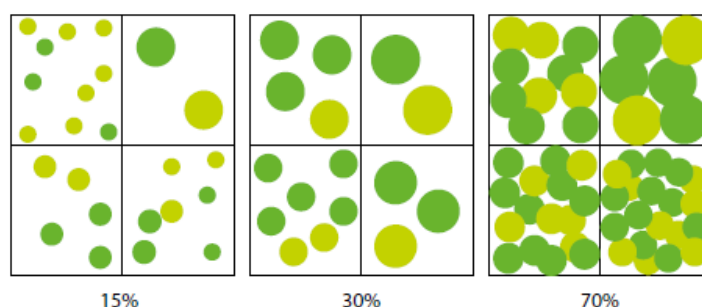

(Source: Guidelines for Planning in Bushfire Prone Areas 2017, Appendix 4)

Shrubs (0.5 metres to 5 metres in height): should not be located under trees or within 3 metres of buildings, should not be planted in clumps greater than 5m² in area, clumps of shrubs should be separated from each other and any exposed window or door by at least 10 metres. Shrubs greater than 5 metres in height are to be treated as trees.

Ground covers (<0.5 metres in height): can be planted under trees but must be properly maintained to remove dead plant material and any parts within 2 metres of a structure, but 3 metres from windows or doors if greater than 100 mm in height. Ground covers greater than 0.5 metres in height are to be treated as shrubs.

Grass: should be managed to maintain a height of 100 mm or less.

The following example diagrams illustrate how the required dimensions of the APZ will be determined by the type and location of the vegetation.

Hazard on one side
 APZ

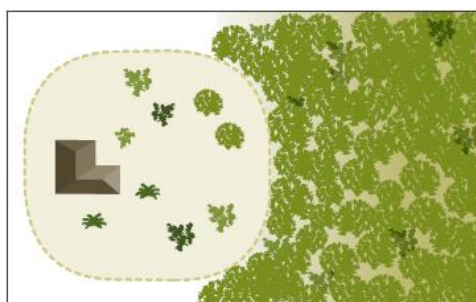

Hazard on three sides
 APZ

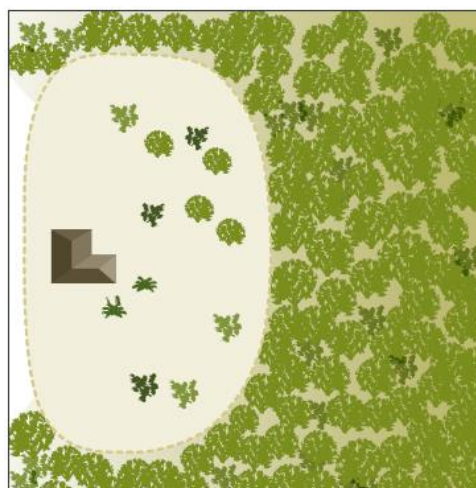

2. Requirements Established by the Local Government – the Firebreak Notice

These requirements are established by the relevant local government’s Firebreak Notice created under s33 of the Bushfires Act 1954 and issued annually (potentially with revisions). The Notice may include additional components directed at managing fuel loads, accessibility and general property management with respect to limiting potential bushfire impact.

The relevant local government’s current Firebreak Notice is available on their website, at their offices and is distributed as ratepayer’s information. It must be complied with.

If Asset Protection Zone technical requirements are defined in the Notice, the standards and dimensions may differ from the Guideline’s APZ Standards, with the intent to better satisfy local conditions. When these are more stringent than those created by the Guidelines, or less stringent and endorsed by the WAPC and DFES, they must be complied with.

When, due to the planning stage of the proposal to which this Bushfire Management Plan applies, defined APZ dimensions are known and are to be applied to existing or future buildings – then these dimensions are stated in Section 5.4.1 of this Plan.

3. Requirements Recommended by DFES – Property Protection Checklists

Further guidance regarding ongoing/lasting property protection (from potential bushfire impact) is presented in the publication ‘DFES – Fire Chat – Your Bushfire Protection Toolkit’. It is available from the Department of Fire and Emergency Services (DFES) website.

4. Requirements Established by AS 3959-2009 - Maintaining Areas within your Lot as 'Low Threat'

This information is provided for reference purposes. This knowledge will assist the landowner to comply with Management Requirement No. 3 set out in the Guidance Panel at the start of this Appendix. It identifies what is required for an area of land to be excluded from classification as a potential bushfire threat.

"Australian Standard - AS 3959-2009 Section 2.2.3.2: Exclusions - Low threat vegetation and non-vegetated areas:

The Bushfire Attack Level shall be classified BAL-LOW where the vegetation is one or a combination of the following:

- a) Vegetation of any type that is more than 100m from the site.*
- b) Single areas of vegetation less than 1ha in area and not within 100m of other areas of vegetation being classified.*
- c) Multiple area of vegetation less than 0.25ha in area and not within 20m of the site or each other.*
- d) Strips of vegetation less than 20m in width (measured perpendicular to the elevation exposed to the strip of vegetation) regardless of length and not within 20m of the site or each other, or other areas of vegetation being classified.*
- e) Non-vegetated areas, including waterways, roads, footpaths, buildings and rocky outcrops.*
- f) Low threat vegetation, including grassland managed in a **minimal fuel condition** (i.e. insufficient fuel available to significantly increase the severity of a bushfire attack – recognisable as short cropped grass to a nominal height of 100mm for example), maintained lawns, golf courses, maintained public reserves and parklands, vineyards, orchards, cultivated gardens, commercial nurseries, nature strips and windbreaks."*

Appendix 2 - Vehicular Access Technical Requirements

Each local government may have their own standard technical requirements for emergency vehicular access and they may vary from those stated in the Guidelines.

Contact the relevant local government for the requirements that are to apply in addition to the requirements set out as an acceptable solution in the Guidelines. If the relevant local government requires that these are included in the Bushfire Management Plan, they will be included in this appendix and referenced.

Requirements Established by the Guidelines – The Acceptable Solutions

(Source: Guidelines for Planning in Bushfire Prone Areas WAPC 2017 v1.3, Appendix 4)

Vehicular Access Technical Requirements - Part 1

Acceptable Solution 3.3: Cul-de-sacs (including a dead-end road)

Their use in bushfire prone areas should be avoided. Where no alternative exists then the following requirements are to be achieved:

- Maximum length is 200m. If public emergency access is provided between cul-de-sac heads (as a right of way or public access easement in gross), the maximum length can be increased to 600m provided no more than 8 lots are serviced and the emergency access way is less than 600m in length;
- Turnaround area requirements, including a minimum 17.5m diameter head to allow type 3.4 fire appliances to turn around safely;
- The cul-de-sac connects to a public road that allows for travel in two directions; and
- Meet the additional design requirements set out in Part 2 of this appendix.

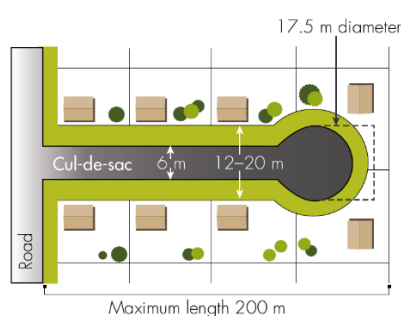

Acceptable Solution 3.4: Battle-axe

Their use in bushfire prone areas should be avoided. Where no alternative exists then the following requirements are to be achieved:

- Maximum length 600m and minimum width 6m; and
- Comply with minimum standards for private driveways.

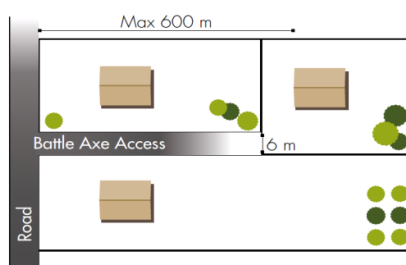

Acceptable Solution 3.5: Private Driveways

The following requirements are to be achieved:

- The design requirements set out in Part 2 of this appendix; and

Where the house site is more than 50 metres from a public road:

- Passing bays every 200 metres with a minimum length of 20 metres and a minimum width of two metres (ie combined width of the passing bay and constructed private driveway to be a minimum six metres);
- Turn-around areas every 500 metres and within 50 metres of a house, designed to accommodate type 3.4 fire appliances to turn around safely (ie kerb to kerb 17.5 metres);
- Any bridges or culverts are able to support a minimum weight capacity of 15 tonnes; and
- All weather surface (i.e. compacted gravel, limestone or sealed).

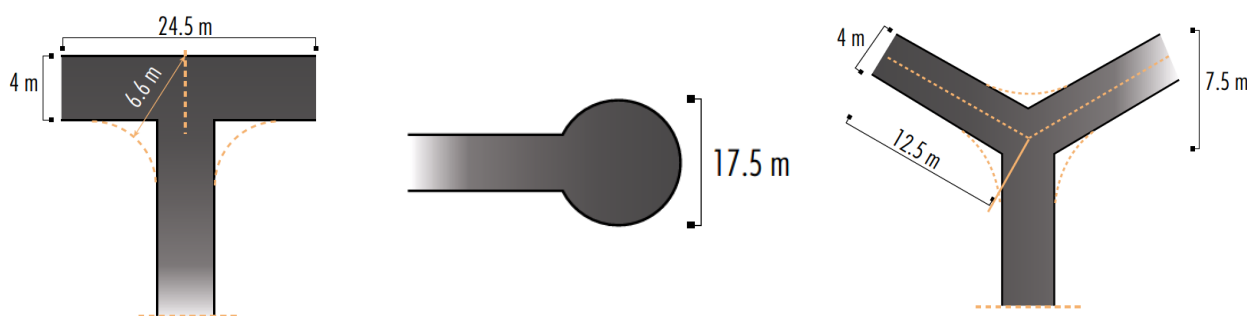

Acceptable Solution 3.6: Emergency Access Way

An access way that does not provide through access to a public road is to be avoided bushfire prone areas. Where no alternative exists, an emergency access way is to be provided as an alternative link to a public road during emergencies. The following requirements are to be achieved:

- No further than 600 metres from a public road;
- Must be signposted including where they ajoin public roads;
- Provided as a right of way or public access easement in gross;
- Where gates are used they must not be locked and they must be a minimum width of 3.6 metres with design and construction approved by local government (refer to the example in this appendix); and
- Meet the additional design requirements set out in Part 2 of this appendix.

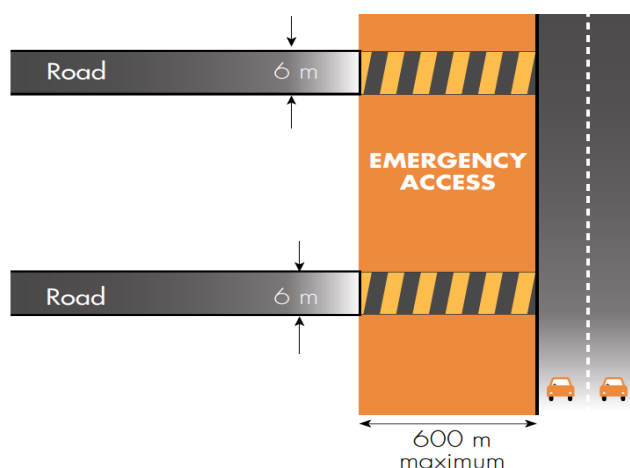

Acceptable Solution 3.7: Fire Service Access Routes (Perimeter Roads)

Are to be established to provide access within and around the edge of subdivision and related development and to provide direct access to bushfire prone areas for firefighters and link between public road networks for firefighting purposes. Fire service access is used during bushfire suppression activities but can also be used for fire prevention work. The following requirements are to be achieved:

- No further than 600 metres from a public road (driveways may be used as part of the designated fire service access;
- Dead end roads not permitted;
- Allow for two-way traffic (i.e. two 3.4 fire appliances);
- Provide turn-around areas designed to accommodate 3.4 fire appliances and to enable them to turn around safely every 500m (i.e. kerb to kerb 17.5 metres);
- All weather surface (i.e. compacted gravel, limestone or sealed) and have erosion control measures in place;
- Must be adequately sign posted;
- Where gates are used they must be a minimum width of 3.6 metres with design and construction approved by local government (refer to the example in this appendix) and may be locked (use a common key system);
- Meet the additional design requirements set out in Part 2 of this appendix;
- Provided as right of ways or public access easements in gross; and
- Management and access arrangements to be documented and in place.

Acceptable Solution 3.8: Firebreak Width

Lots greater than 0.5 hectares must have an internal perimeter firebreak of a minimum width of three meters or to the level as prescribed in the local firebreak notice issued by the local government.

Vehicular Access Technical Requirements - Part 2

Technical Component	Vehicular Access Types				
	Public Roads	Cul-de-sacs	Private Driveways	Emergency Access Ways	Fire Service Access Routes
Minimum trafficable surface (m)	6*	6	4	6*	6*
Horizontal clearance (m)	6	6	6	6	6
Vertical clearance (m)	4.5	4.5	4.5	4.5	4.5
Maximum grade <50 metres	1 in 10	1 in 10	1 in 10	1 in 10	1 in 10
Minimum weight capacity (t)	15	15	15	15	15
Maximum cross-fall	1 in 33	1 in 33	1 in 33	1 in 33	1 in 33
Curves minimum inner radius (m)	8.5	8.5	8.5	8.5	8.5

* A six metre trafficable surface does not necessarily mean paving width. It could, for example, include four metres of paving and one metre of constructed road shoulders. In special circumstances, where 8 lots or less are being serviced, a public road with a minimum trafficable surface of four metres for a maximum distance of ninety metres may be provided subject to the approval of both the local government and DFES.

Vehicular Access Technical Requirements – Gates and Signs Examples

Gates

Design and construction to be approved by relevant local government.

- Minimum width 3.6m
- Emergency access way gates must not be locked.
- Fire service access route gates may be locked but only with a common key that is available to local fire service personnel.
- Bollards will be to the relevant local government specifications

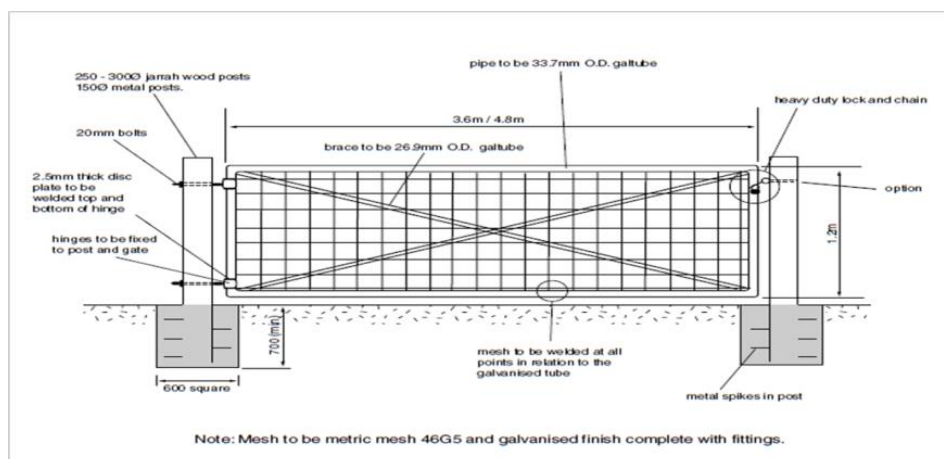

Signs

Design and construction to be approved by the relevant local government.

Minimum height above ground of 0.9m.

Lettering height to be 100mm.

To display the words (as appropriate) “Emergency Access Only” or “Fire Service Access – No Public Access”.

Size 600mm x 400mm.

Sign colour red, base (white) area is reflective background.

Rounded corners, radius 20mm.

White key-line 3mm wide, 3mm from outside edge.

Suggested mounting hole six 6mm diameter.



Appendix 3 - Water Technical Requirements

Requirements Established by the Guidelines - Acceptable Solution A4.1: Reticulated Areas

(Source: Guidelines for Planning in Bushfire Prone Areas WAPC 2017 v1.3, Appendix 4, Element 4)

The requirement is to supply a reticulated water supply and fire hydrants, in accordance with the technical requirements of the relevant water supply authority and DFES.

The Water Corporation's 'No 63 Water Reticulation Standard' is deemed to be the baseline criteria for developments and should be applied unless local water supply authority's conditions apply.

Key specifications in the most recent version/revision of the design standard include:

- **Residential Standard** – hydrants are to be located so that the maximum distance between the hydrants shall be no more than 200 metres.
- **Commercial Standard** – hydrants are to be located with a maximum of 100 metre spacing in Industrial and Commercial areas.
- **Rural Residential Standard** – where minimum site areas per dwelling is 10,000 m² (1ha), hydrants are to be located with a maximum 400m spacing. If the area is further subdivided to land parcels less than 1ha, then the residential standard (200m) is to be applied.

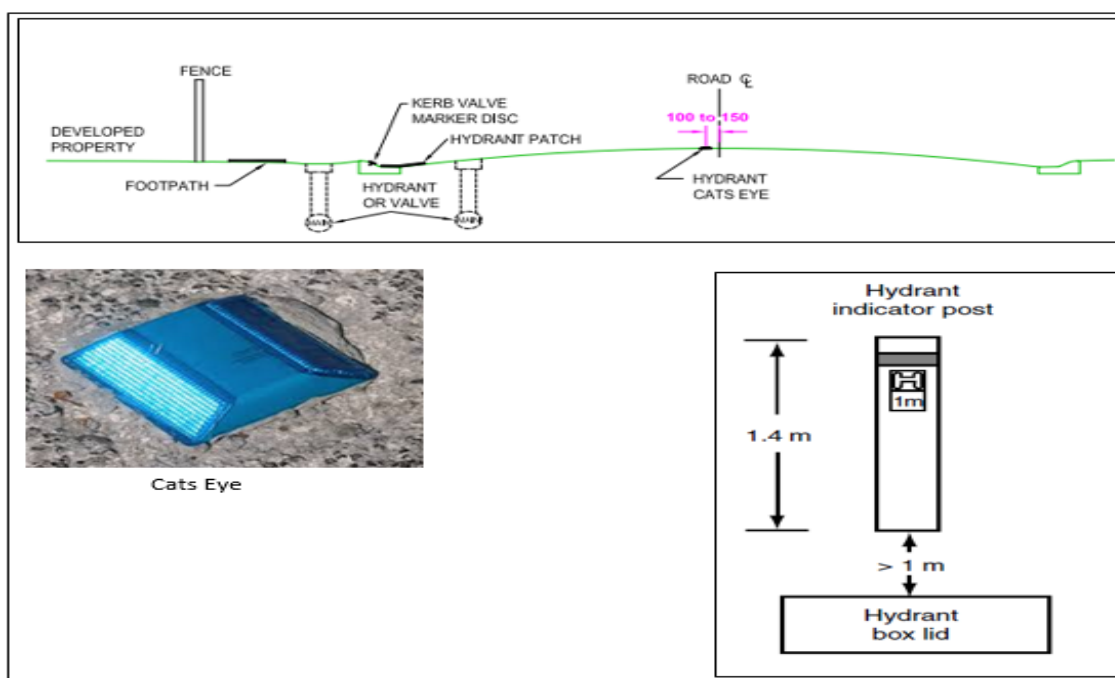

Figure A4.1: Hydrant Location and Identification Specifications

Contact the relevant water supply authority to confirm the technical requirements that are to be applied. They may differ from the minimum requirements of the 'baseline' Water Corporation's No. 63 Water Reticulation Standard.